

Sauna 280, D 200

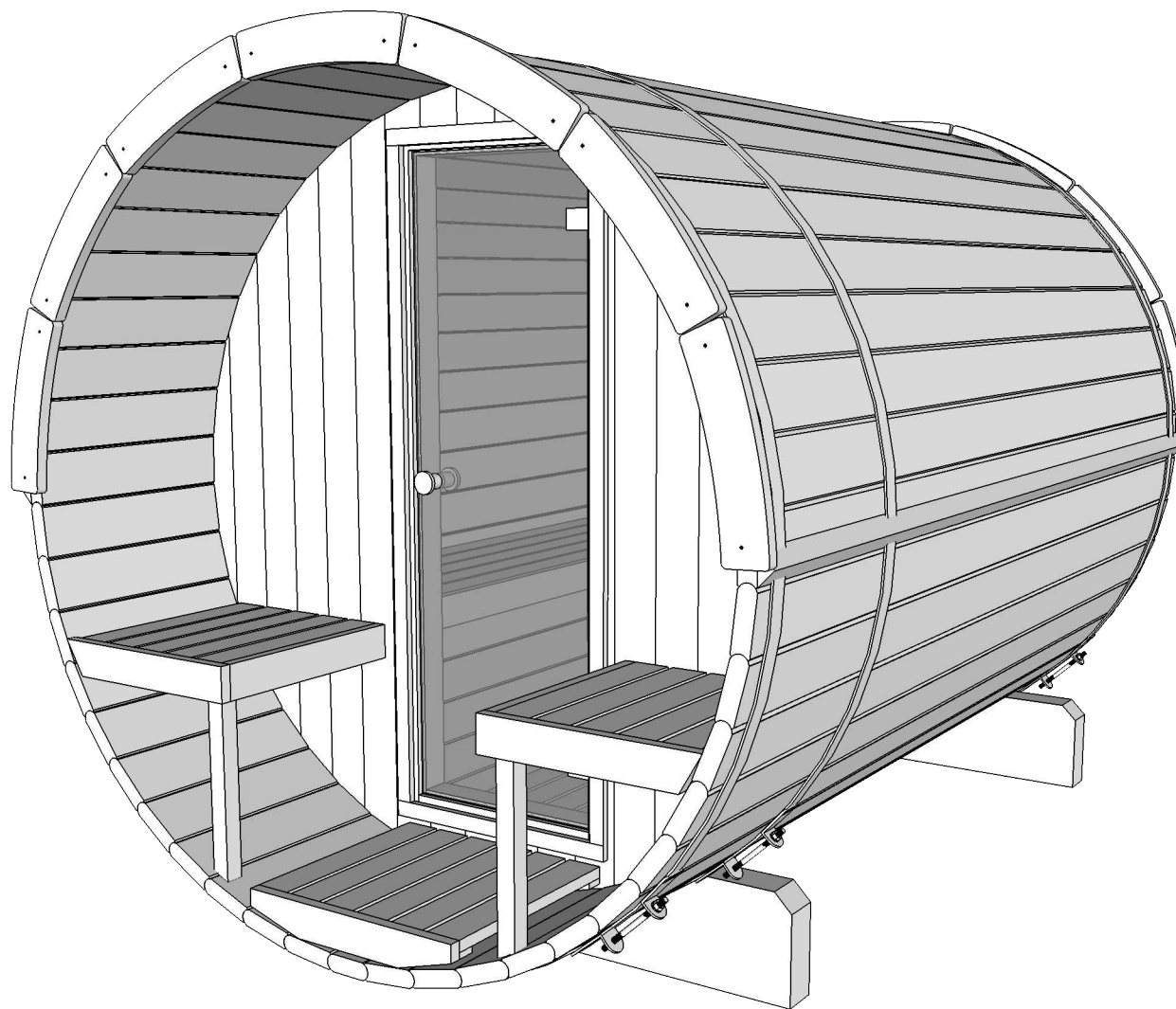

SAUNA 280, D200

Stückliste Nr. 1

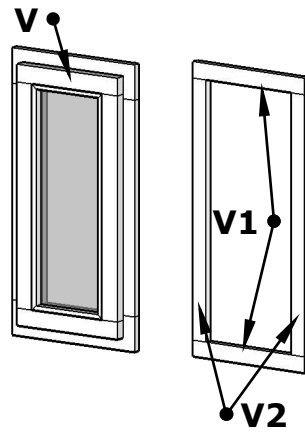
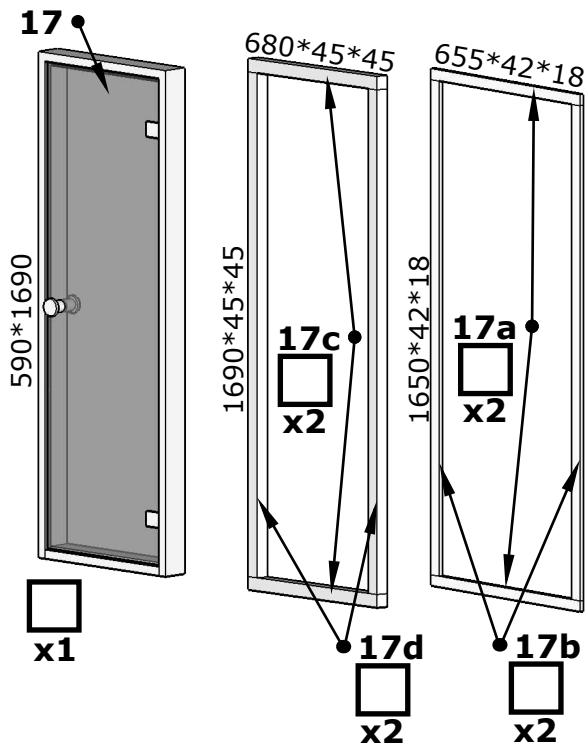
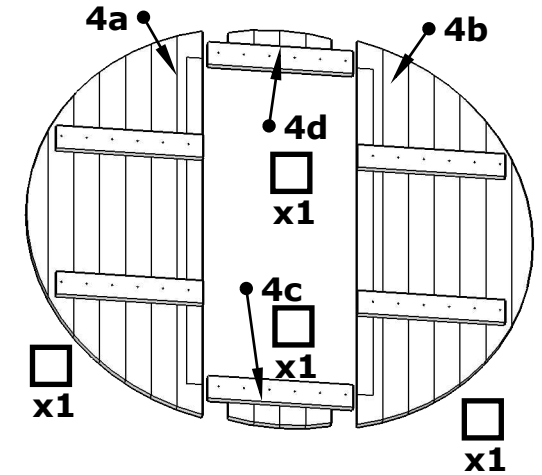
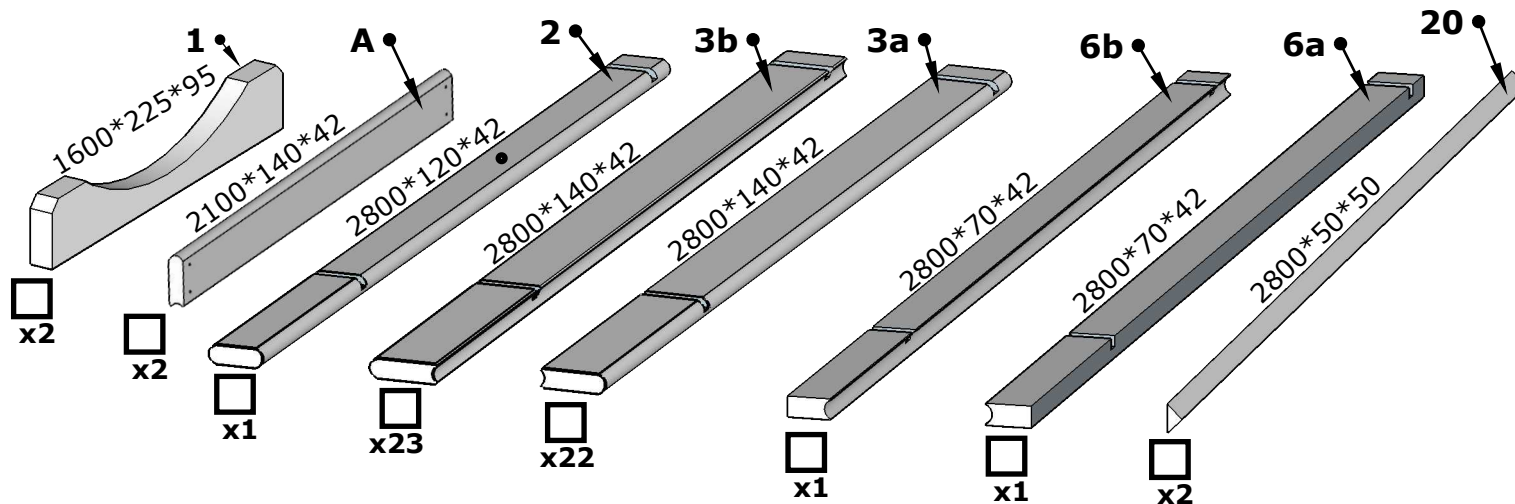

NB! Fenster gehören NICHT zu jedes Model!

NB! Montage von Fenster siehe bitte an Seite 17.

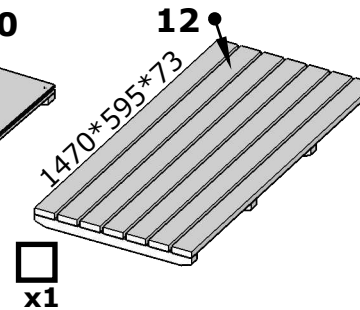
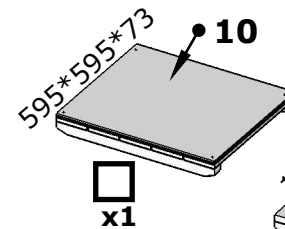
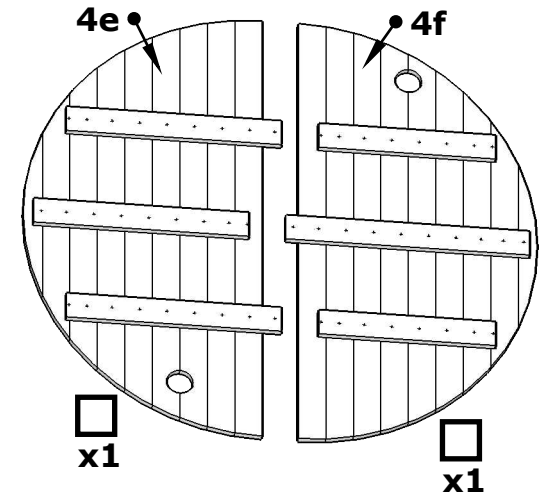
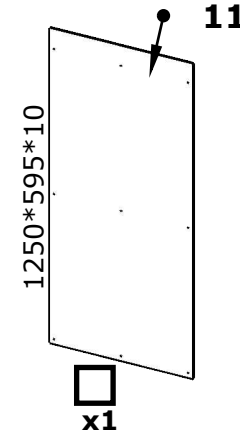

SAUNA 280, D200

Stückliste Nr. 2

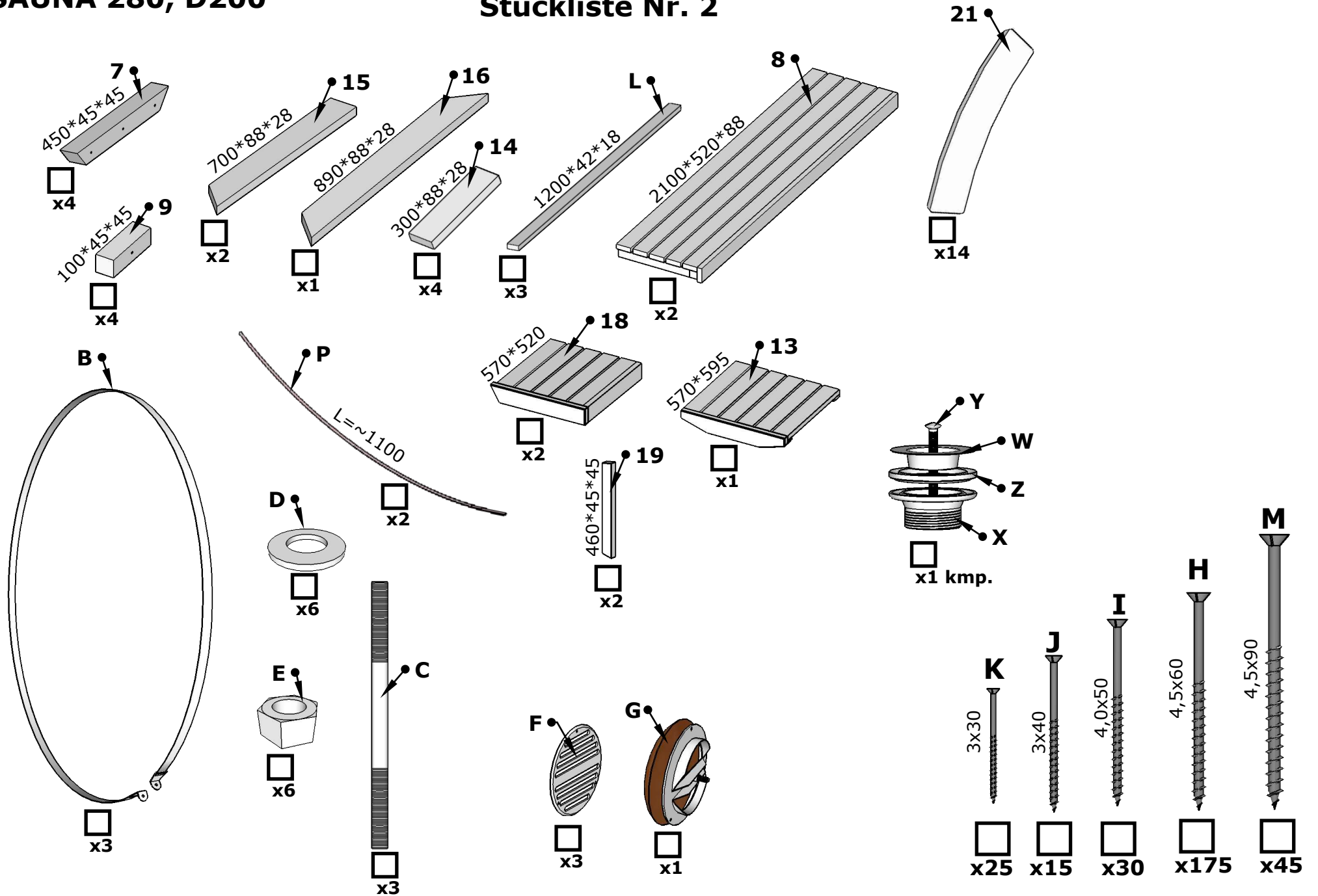

SAUNA 280, D200

Stückliste Nr. 1

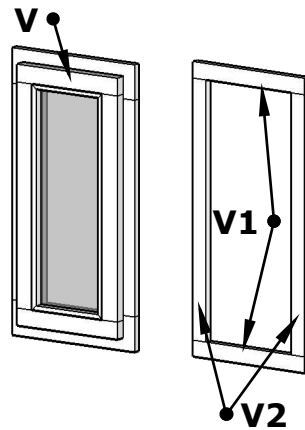
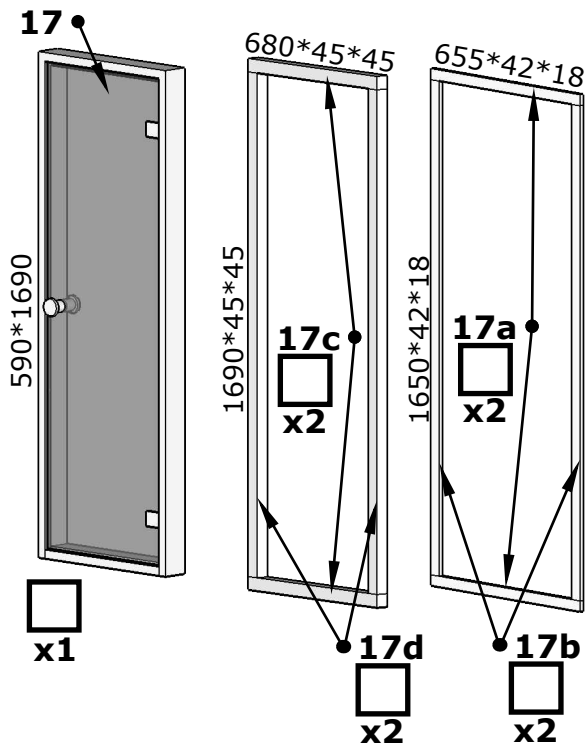
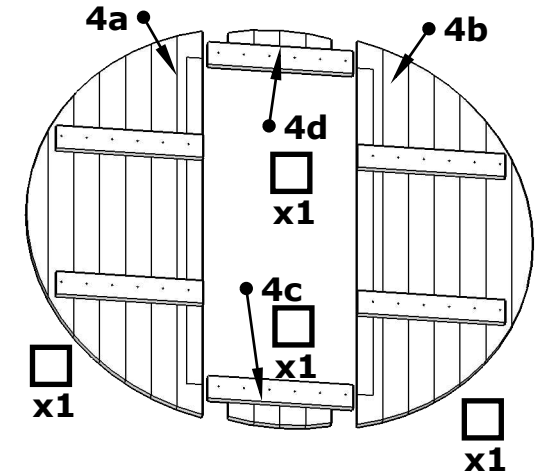
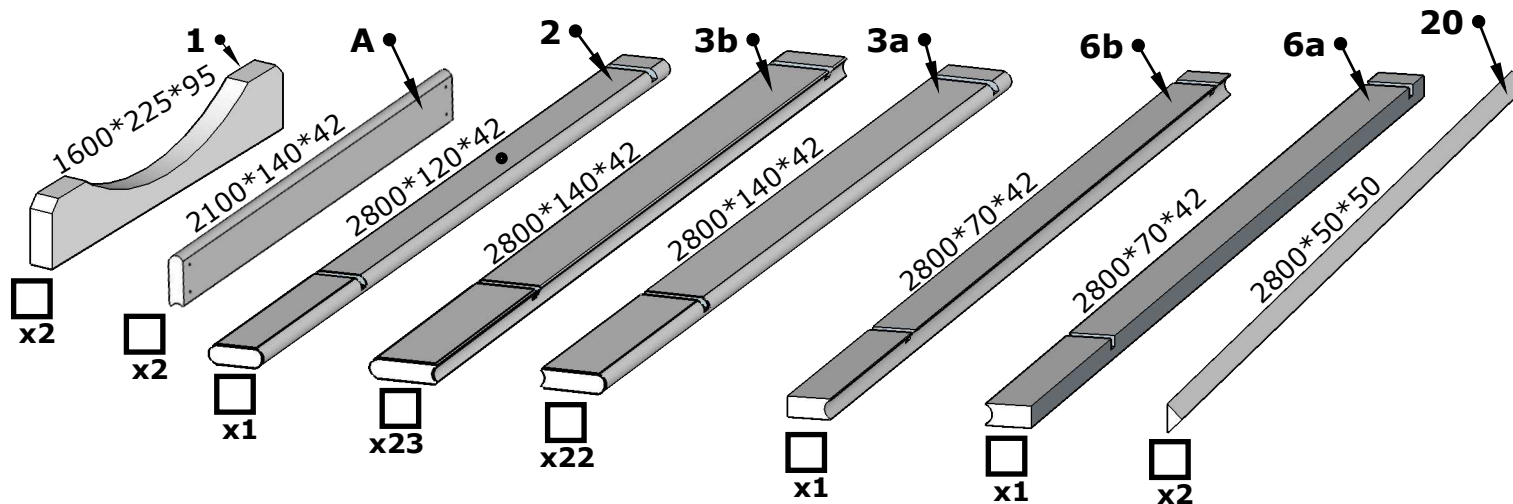

NB! Fenster gehören NICHT zu jedes Model!

NB! Montage von Fenster siehe bitte an Seite 17.

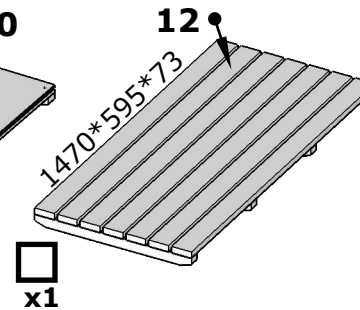
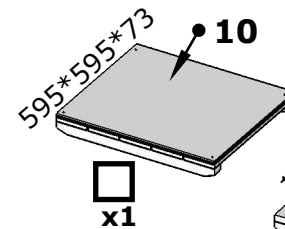
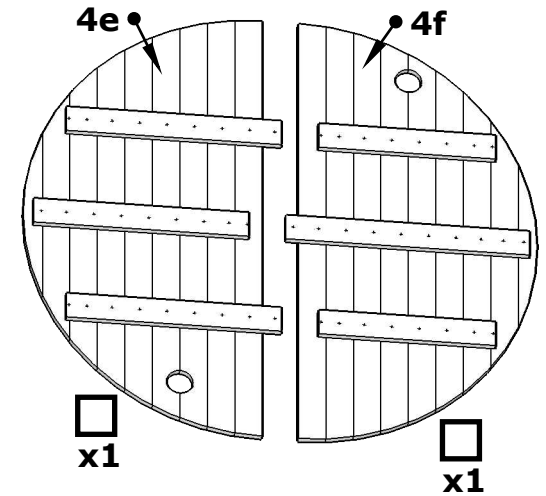
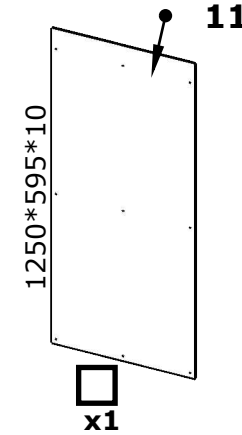

SAUNA 280, D200

Stückliste Nr. 2

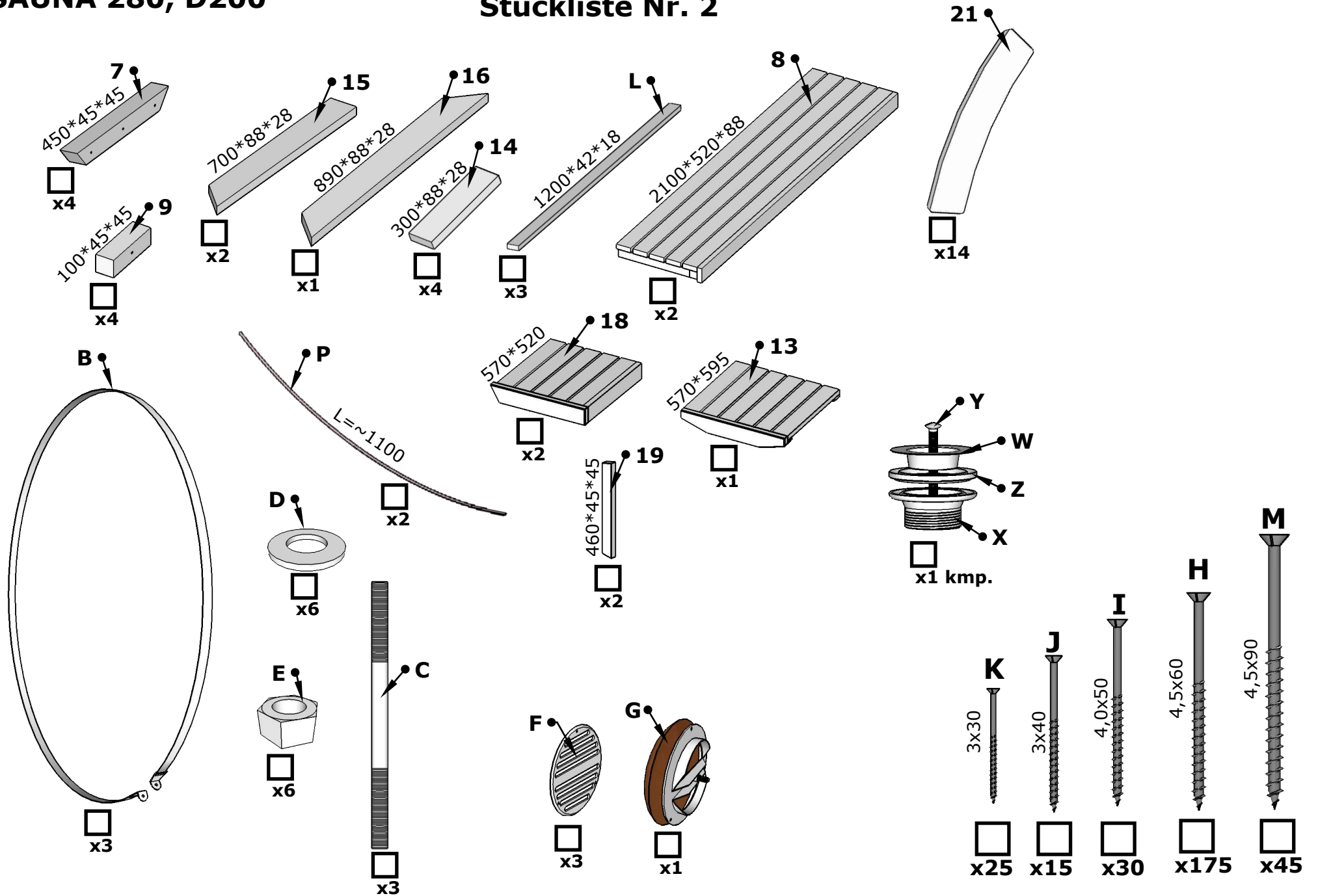

Sauna 280, D 200

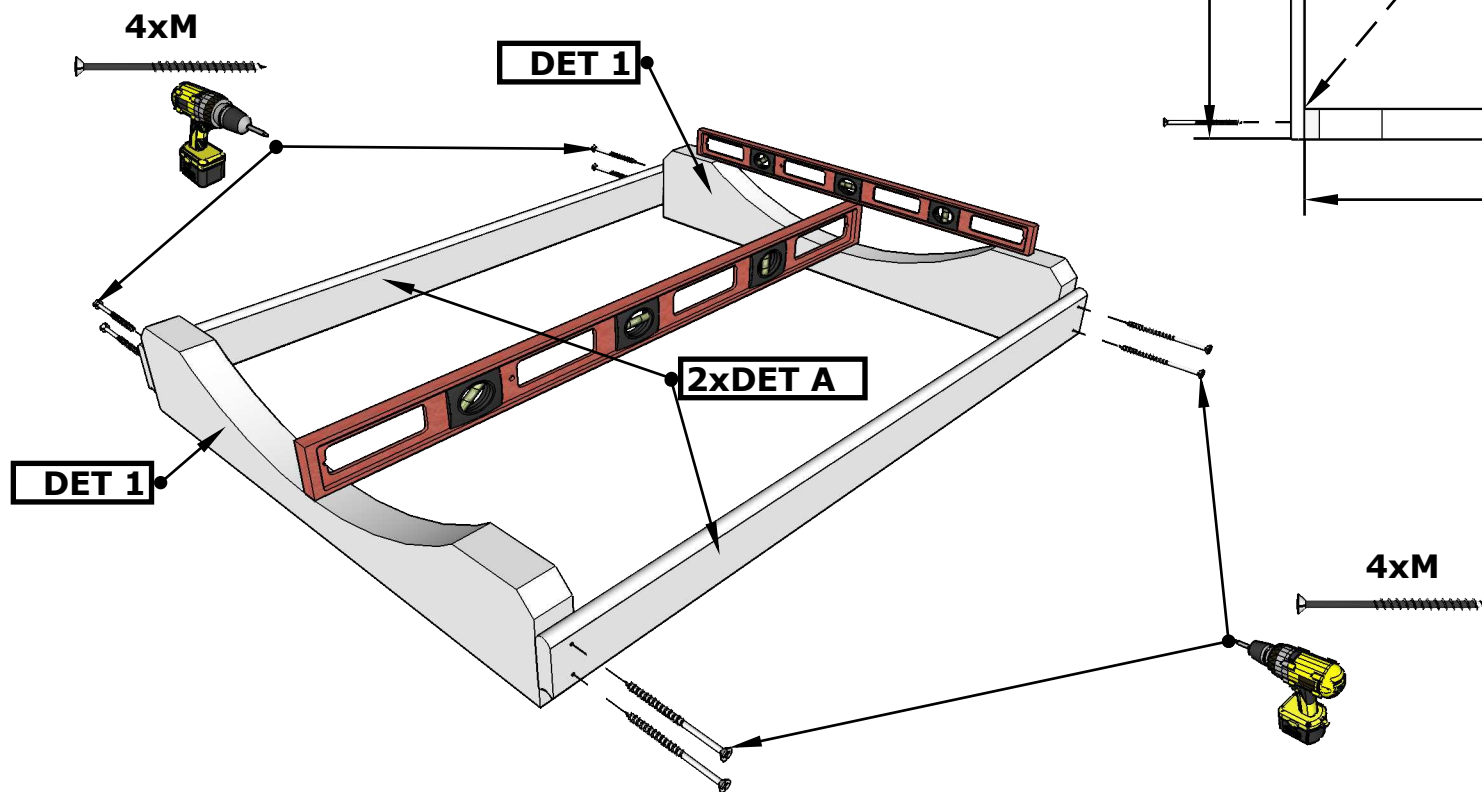
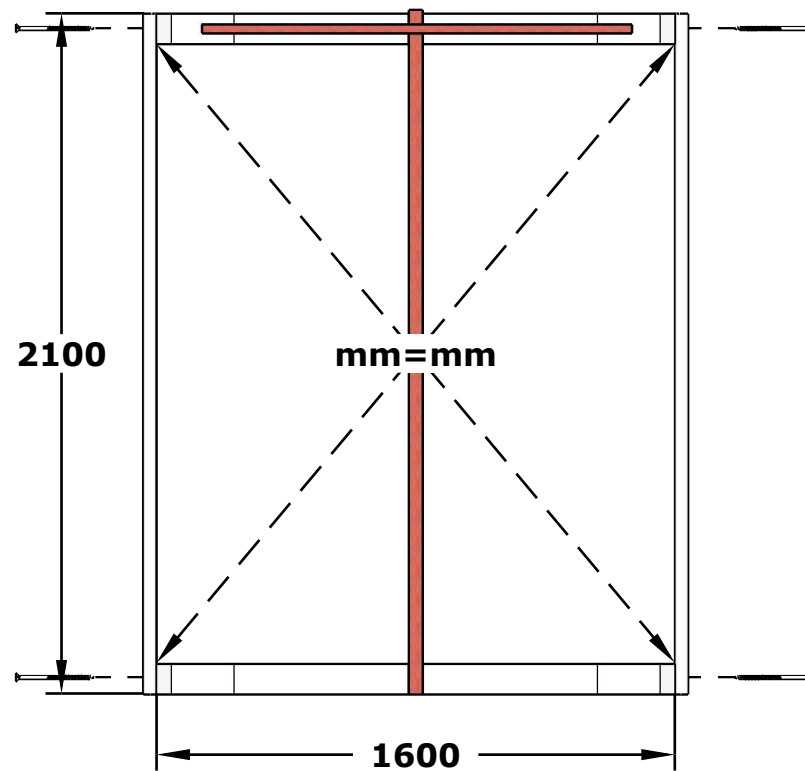
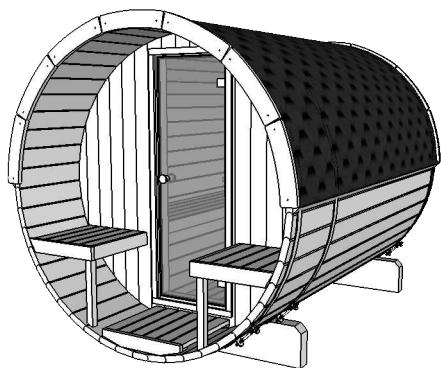

1.

Sauna 280, D 200

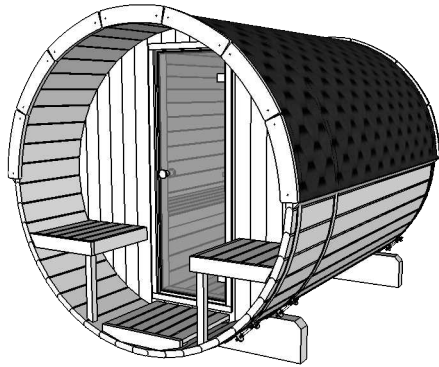

4 x DET 3a
4 x DET 3b

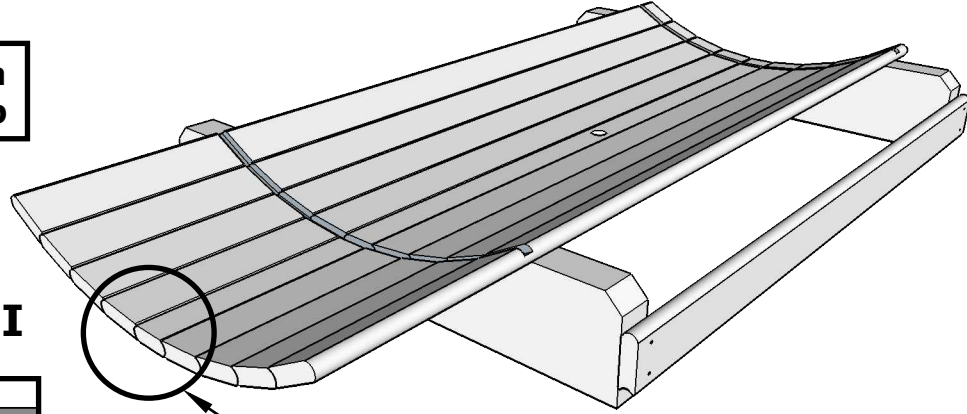

II

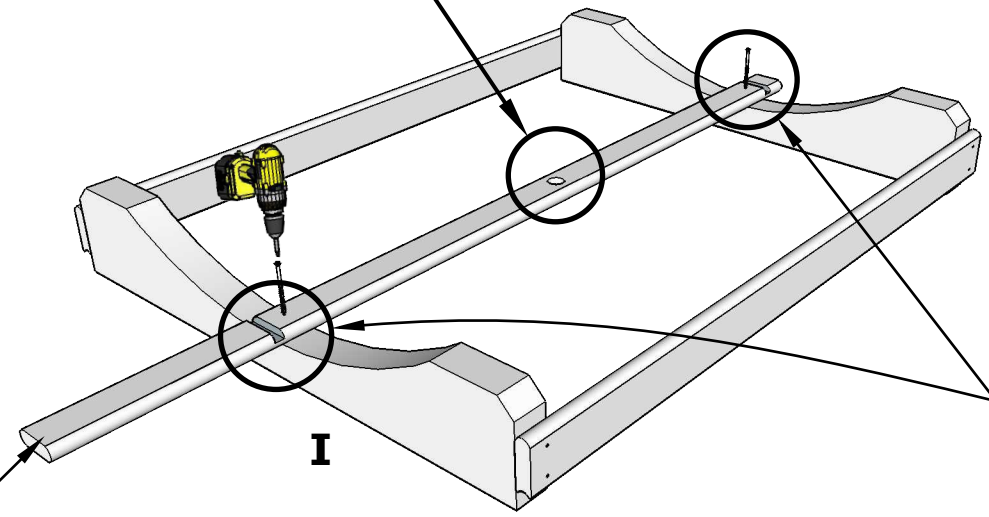
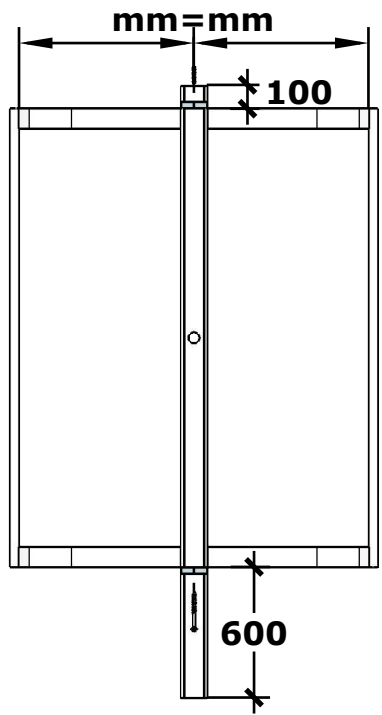
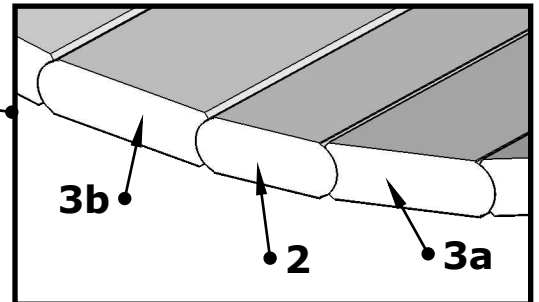
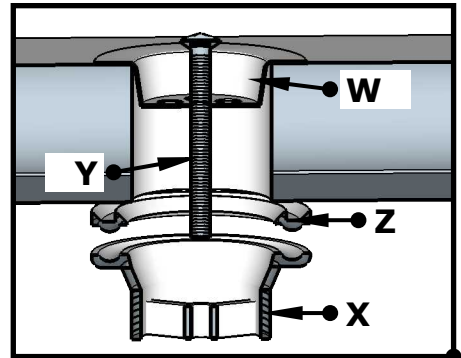

I

1x DET 2

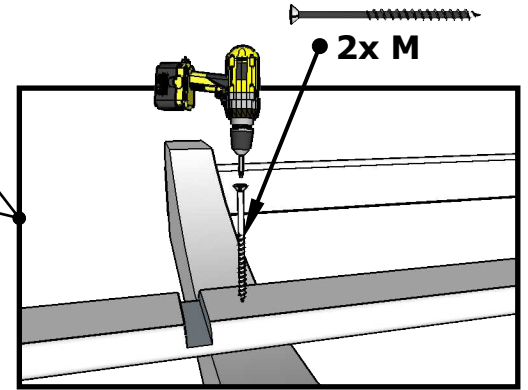

2.

Sauna 280, D 200

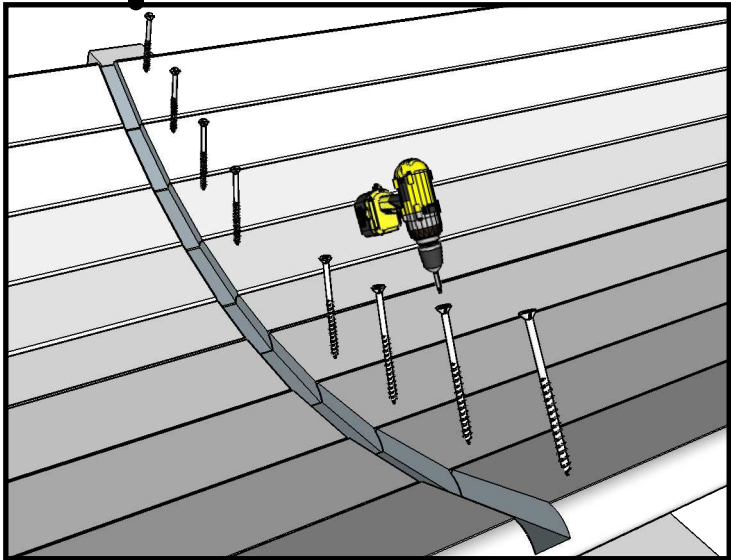
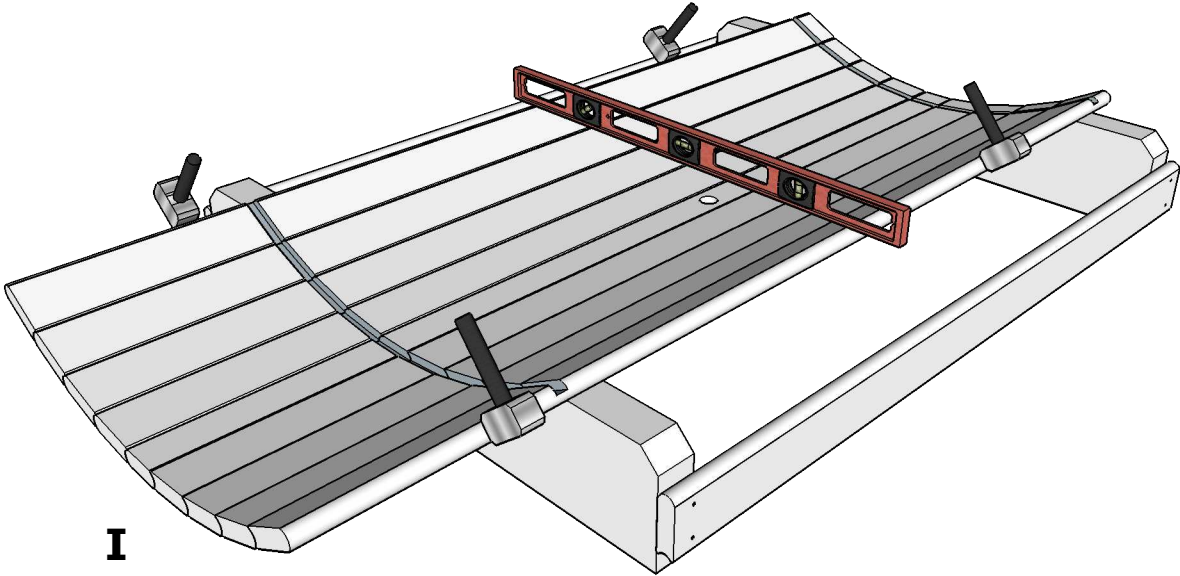
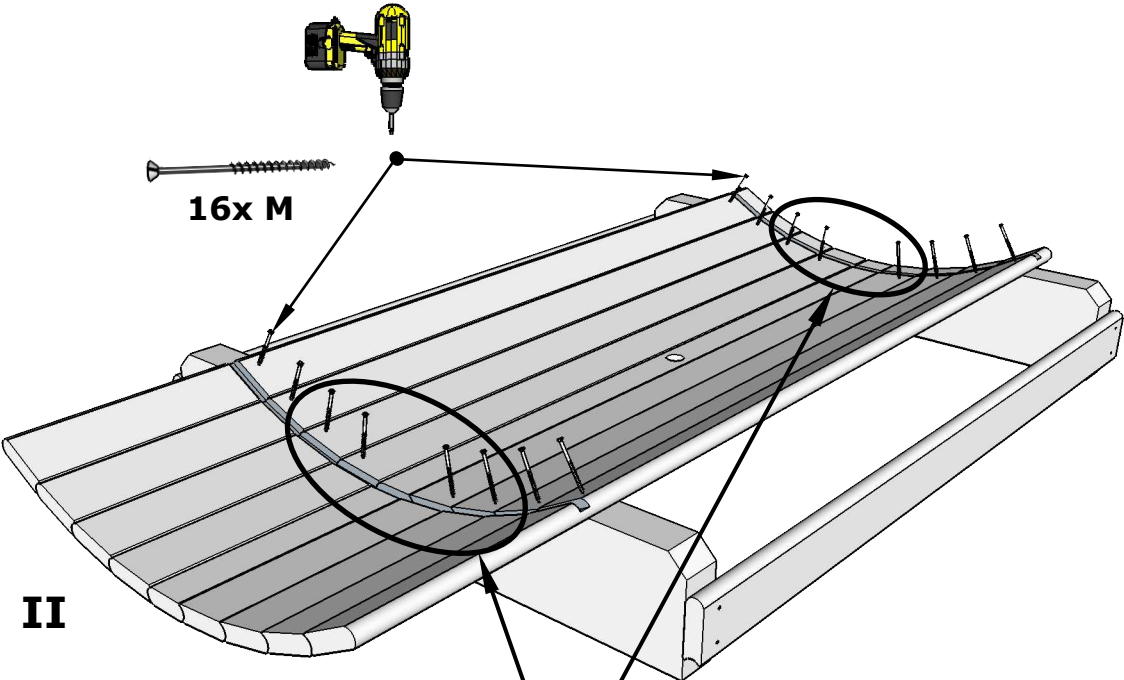
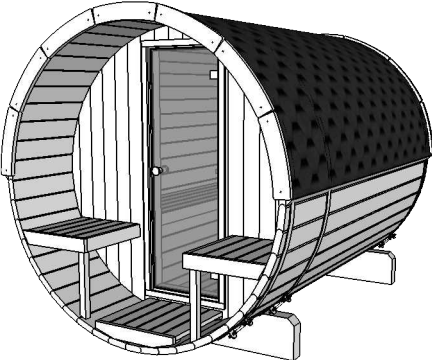

3.

Sauna 280, D 200

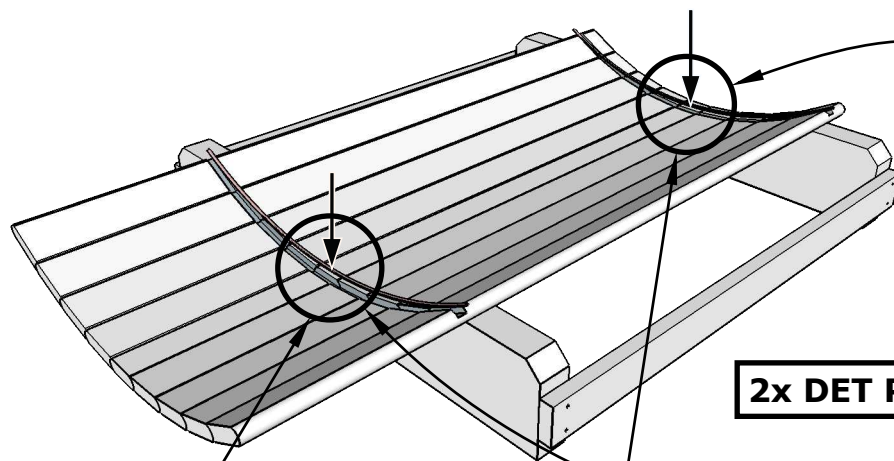
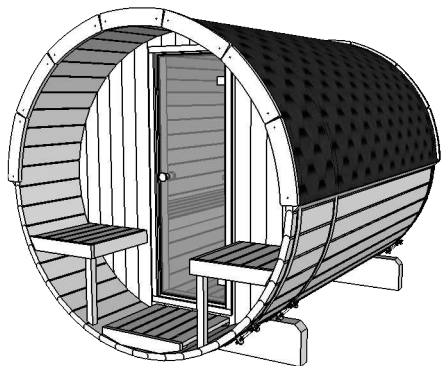

2x DET P

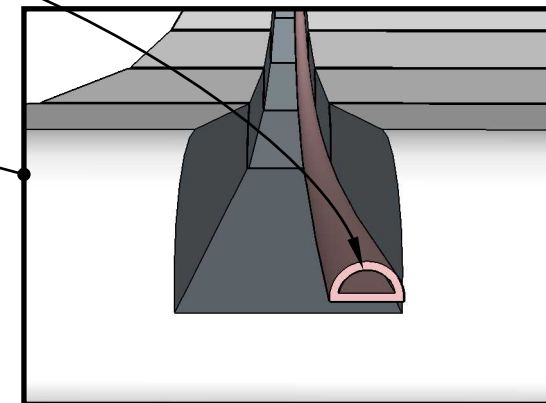
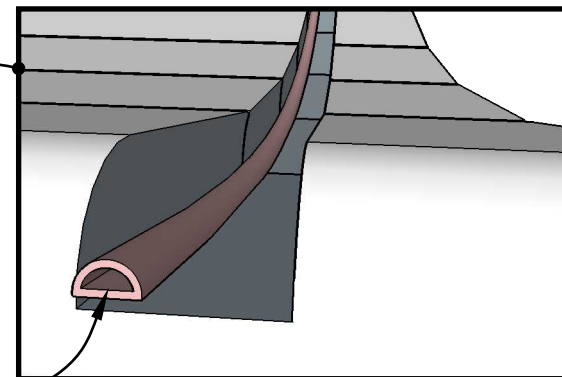

Bohren Sie 4 Löcher in
DET 2 Ø10 mm

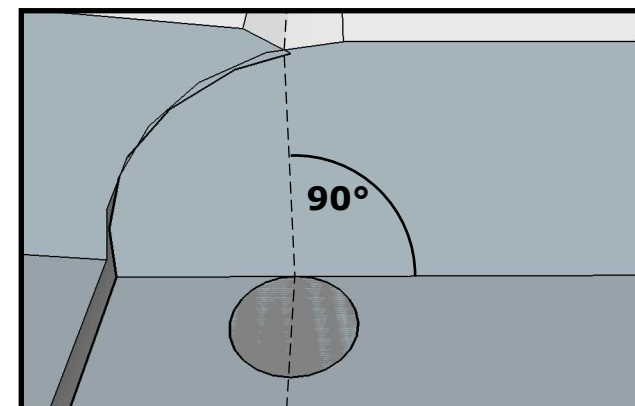
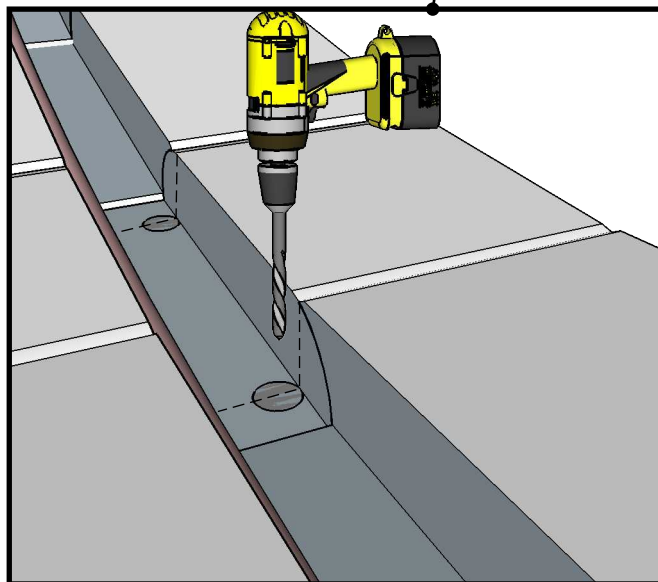
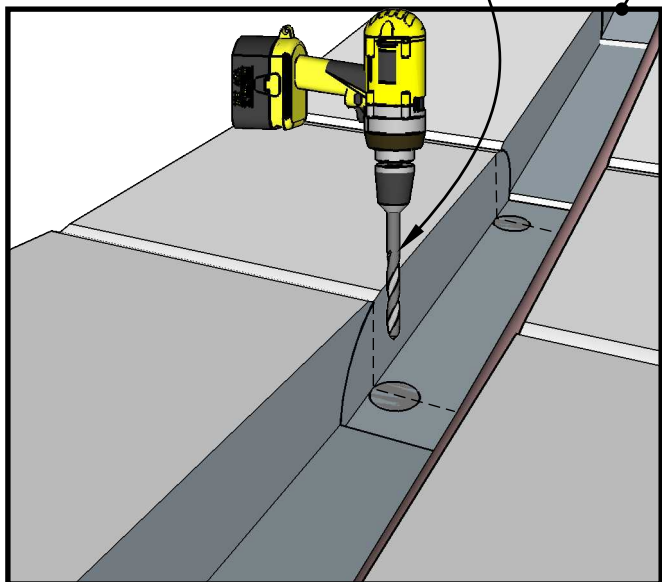

3A.

Sauna 280, D 200

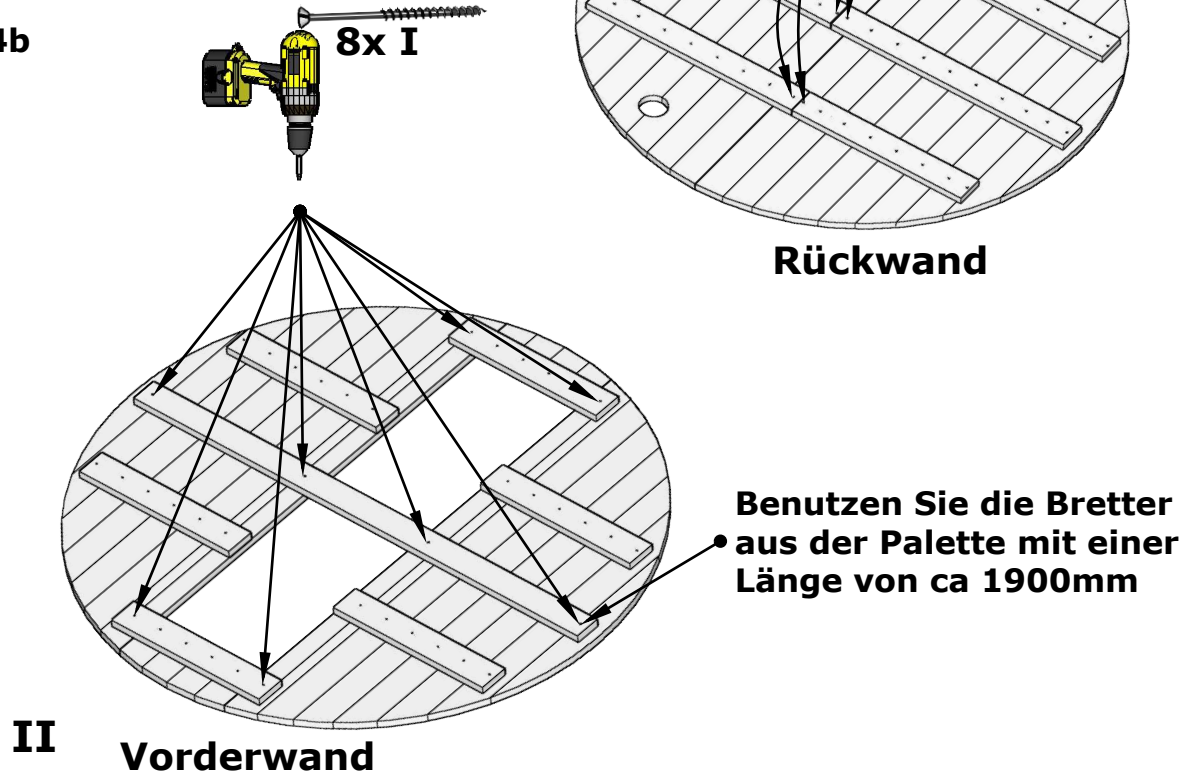
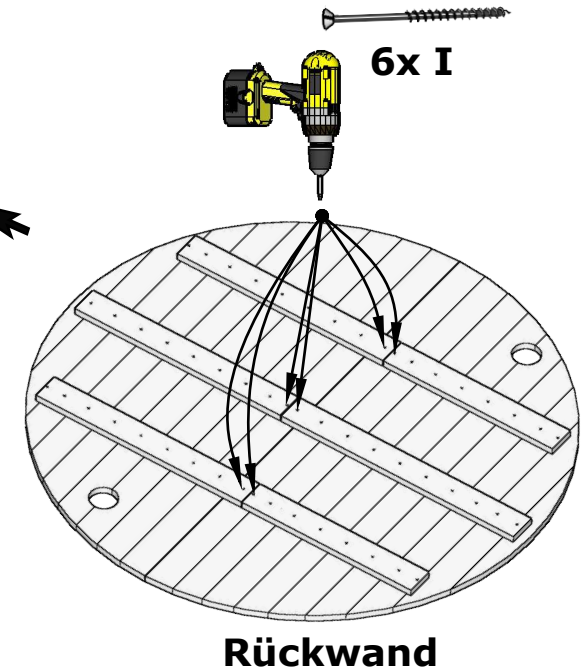
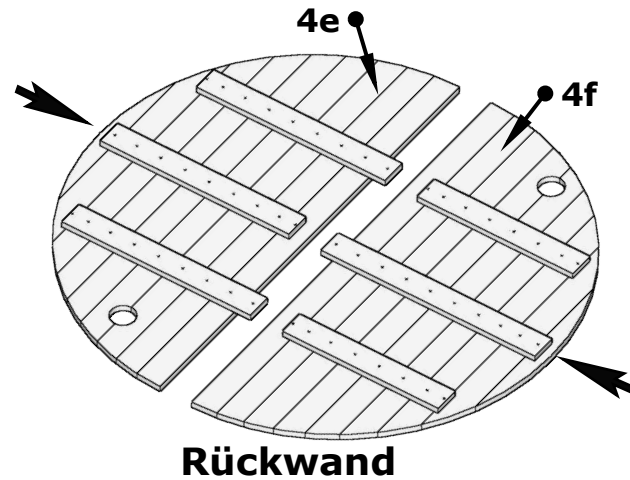
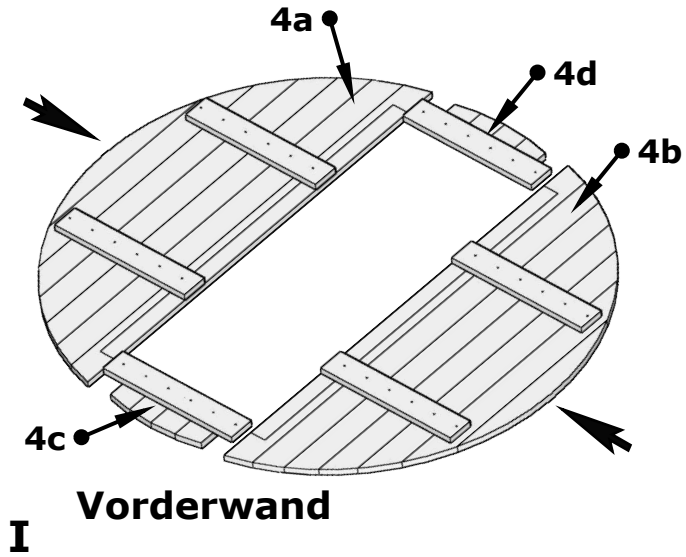
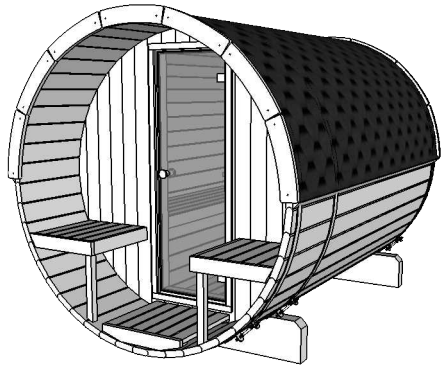

Sauna 280, D 200

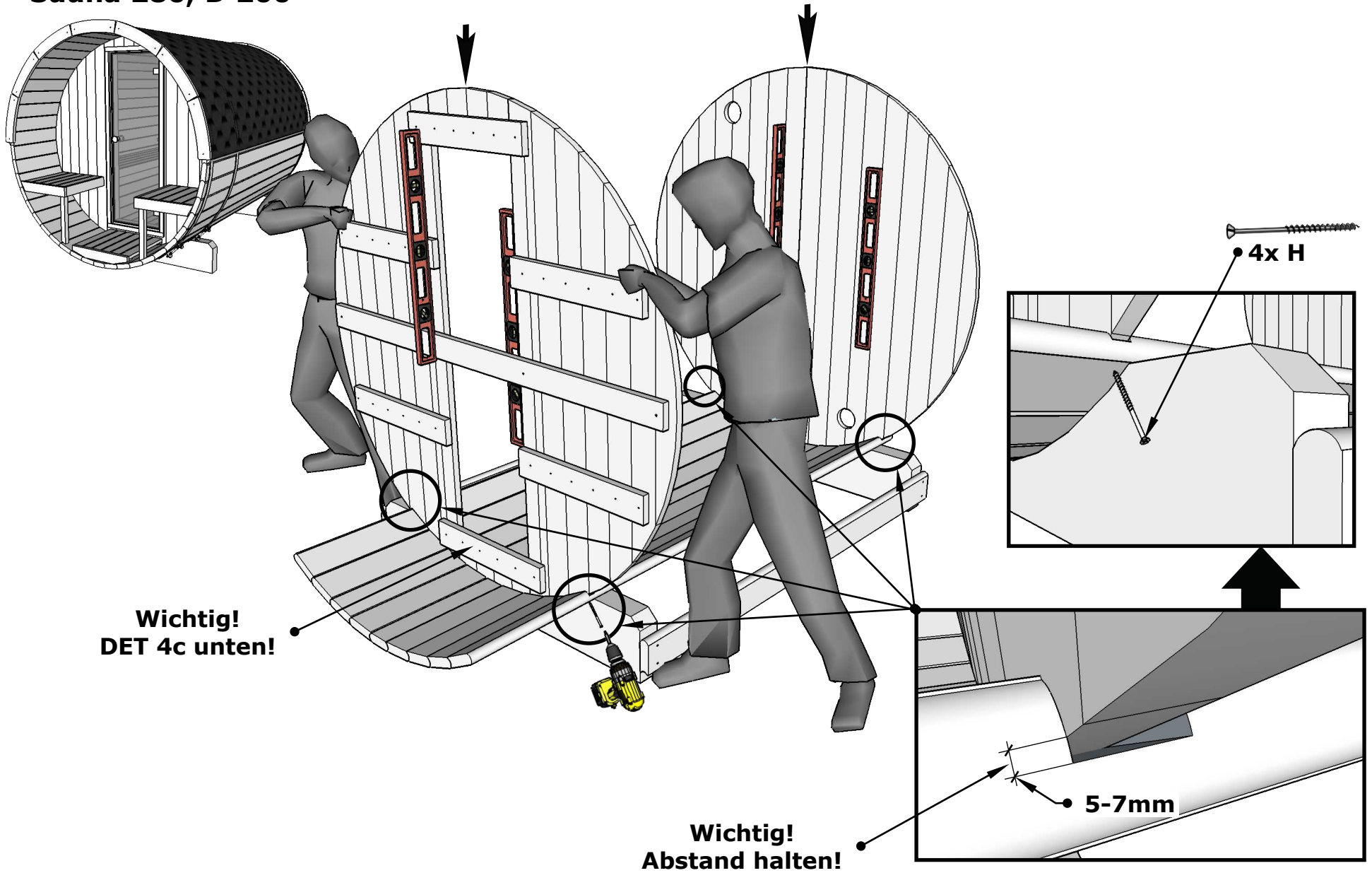

Sauna 280, D 200

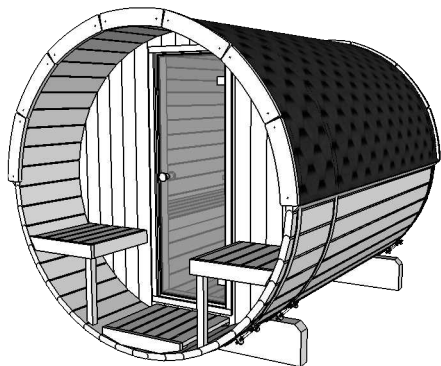

Siehe Seite 6A

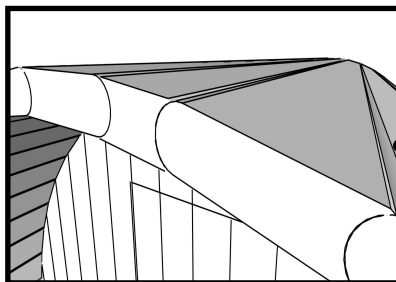

10x DET 3a
11x DET 3b

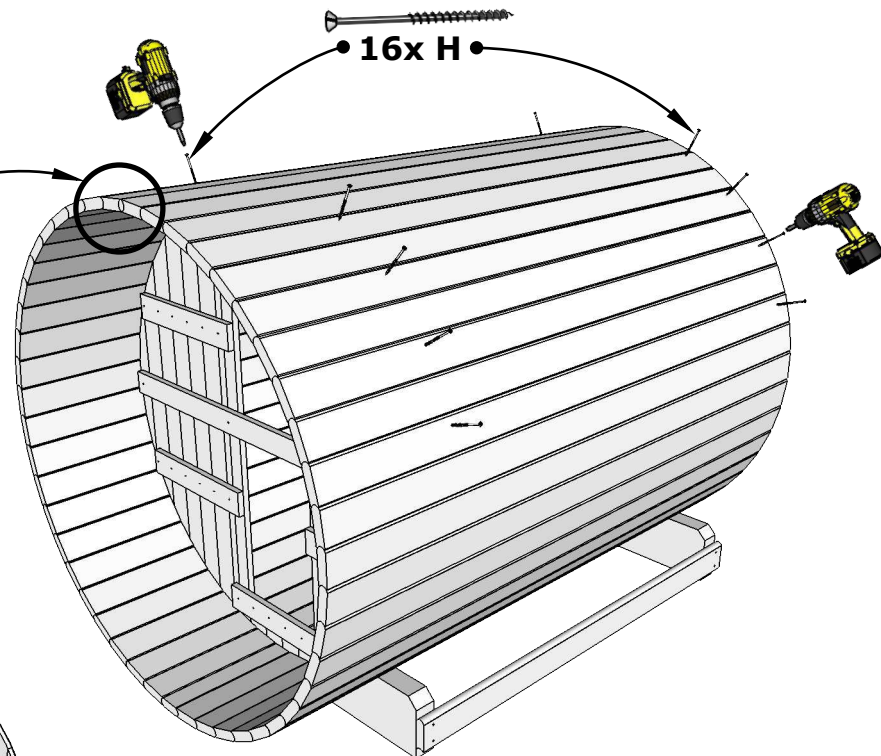

II

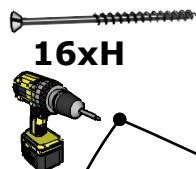
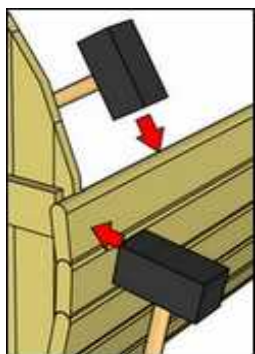

16xH

8x DET 3a
8x DET 3b

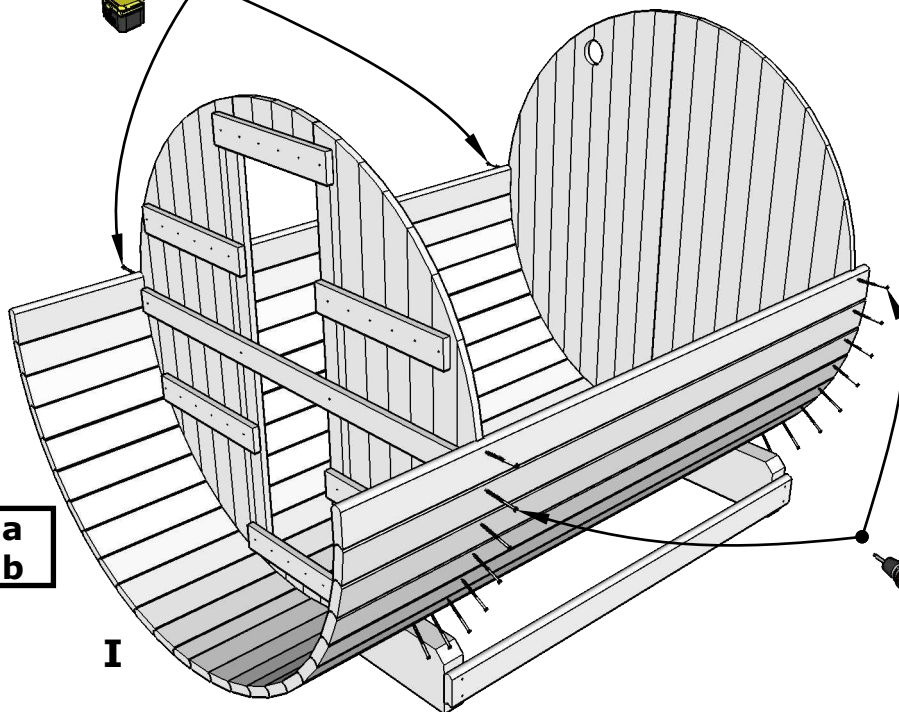

I

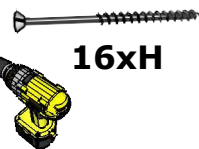

16xH

Sauna 280, D 200

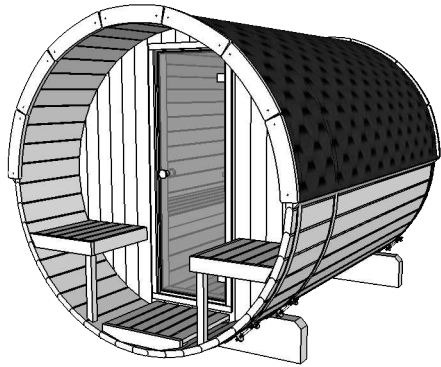

Wichtig!!!

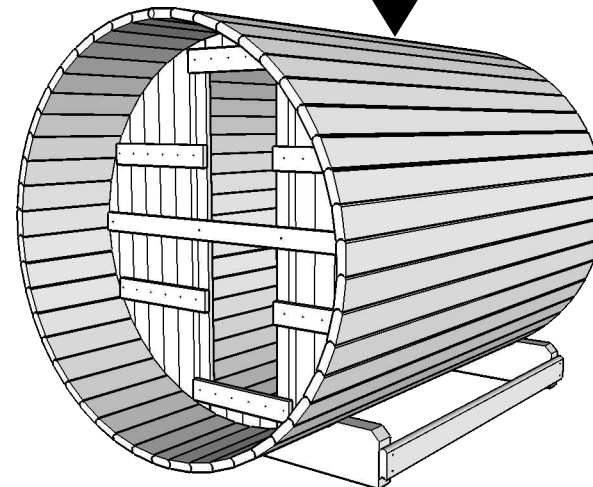
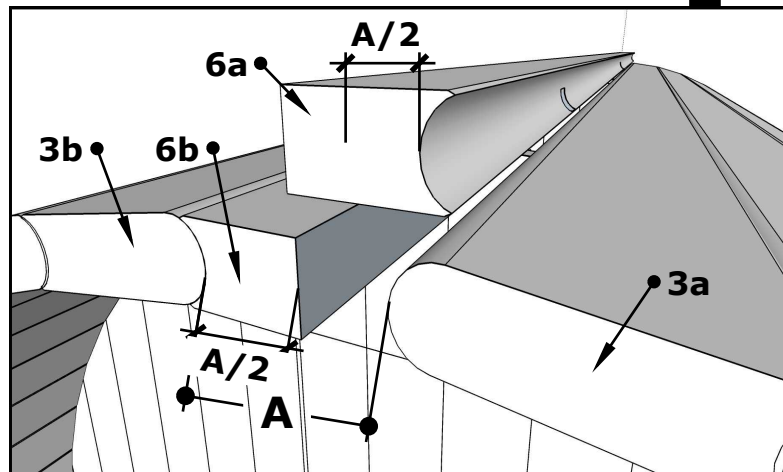
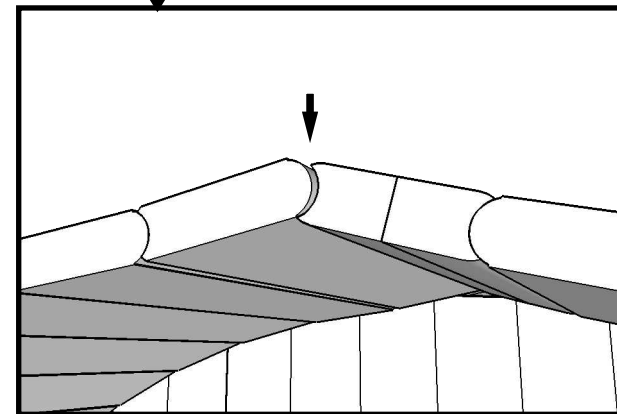
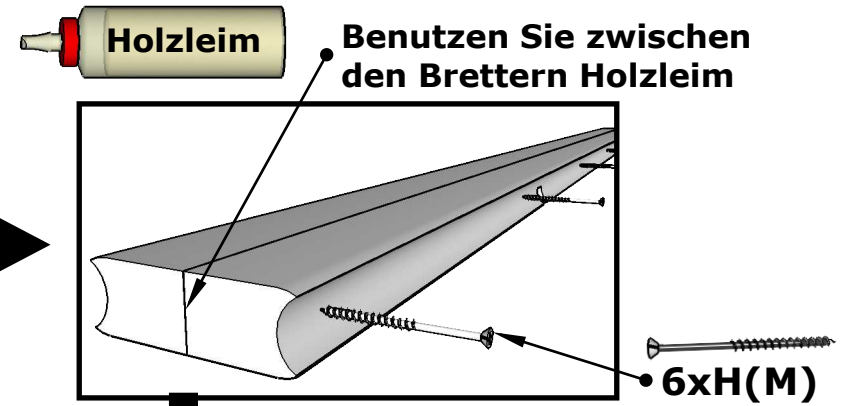
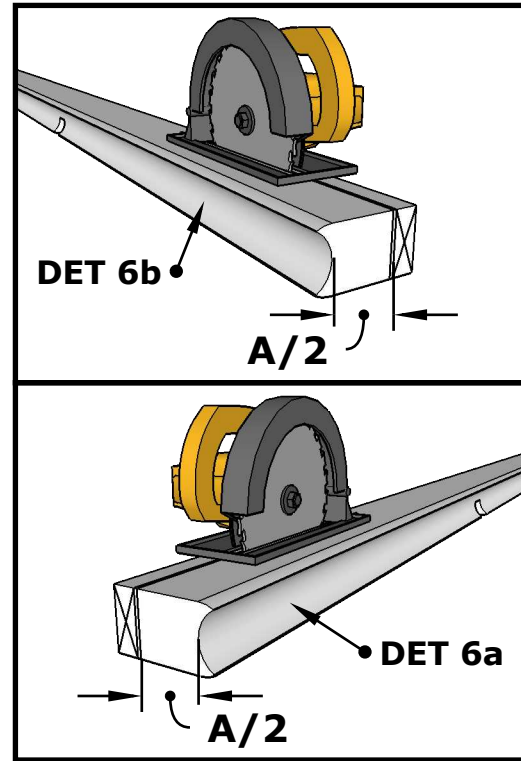

6A.

Sauna 280, D 200

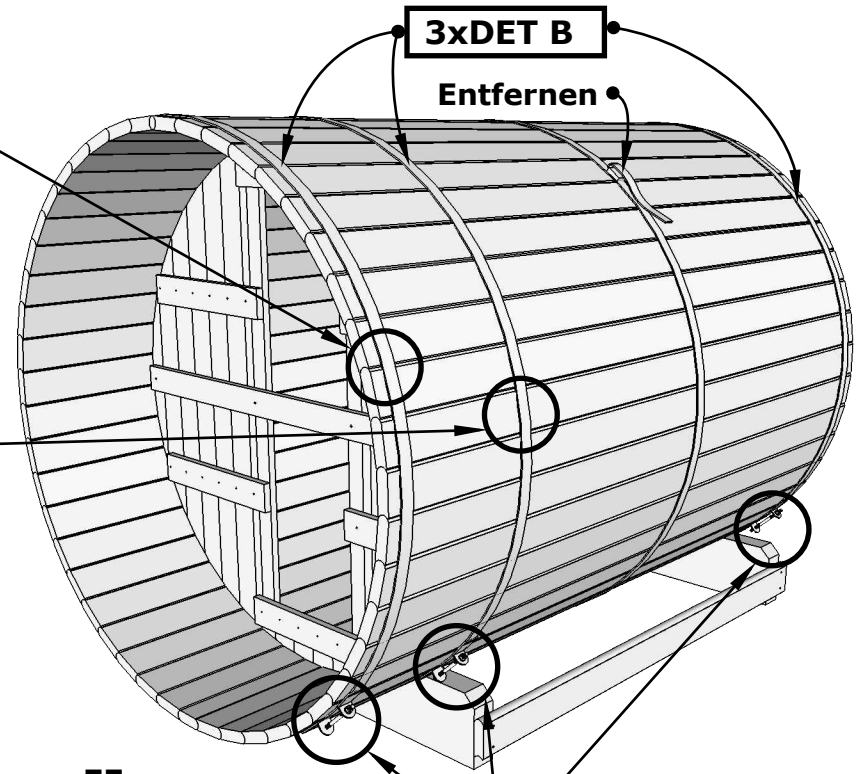
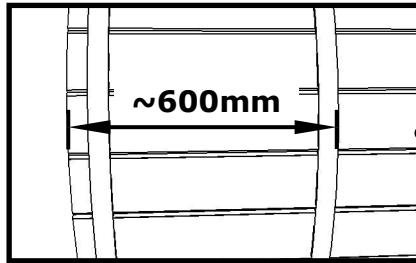
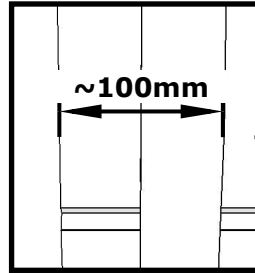
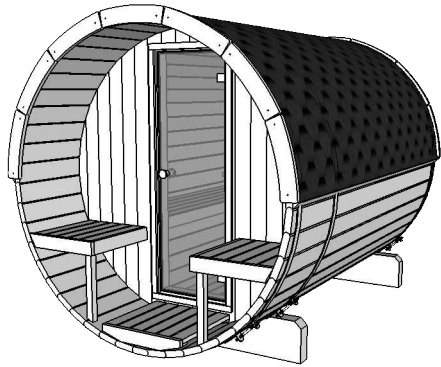

Die Schrauben entfernen



Benutzen Sie ein Spannband

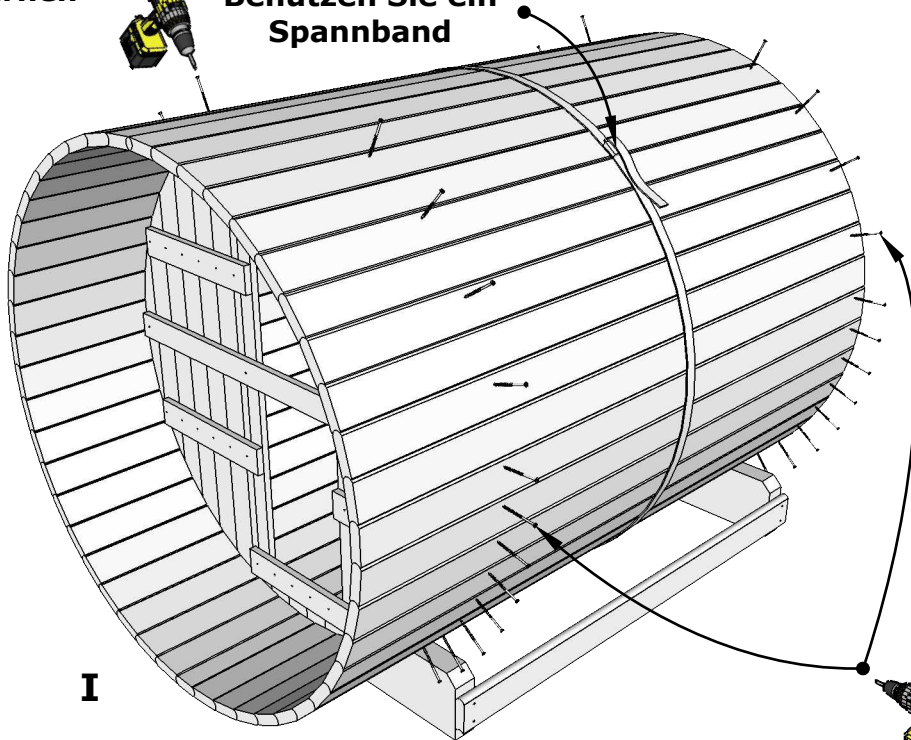

II

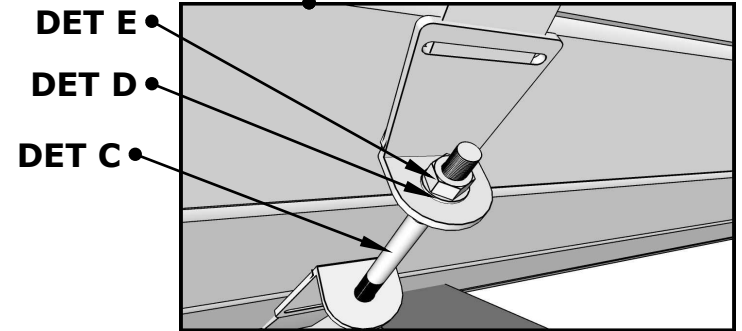

Die Schrauben entfernen

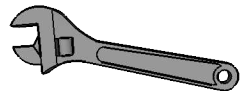

Sauna 280, D 200

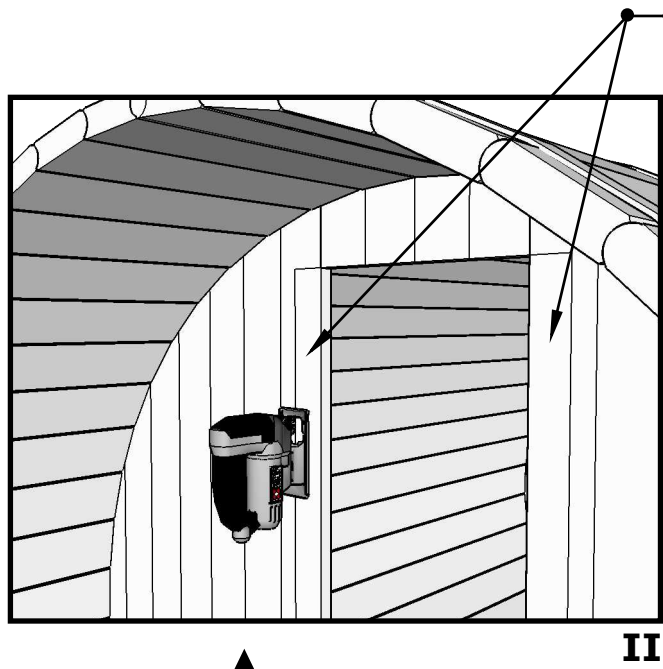
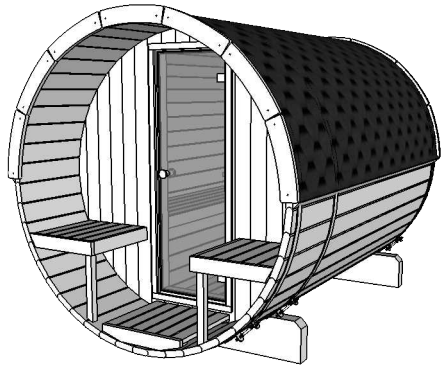

Beachten Sie beim Schneiden die Leitlinien

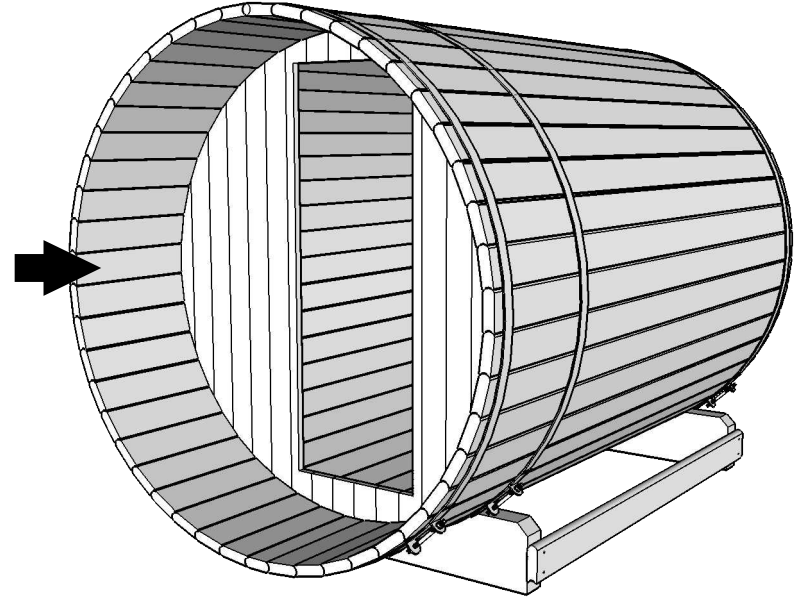

II

Die gezeigten Bretter bitte entfernen

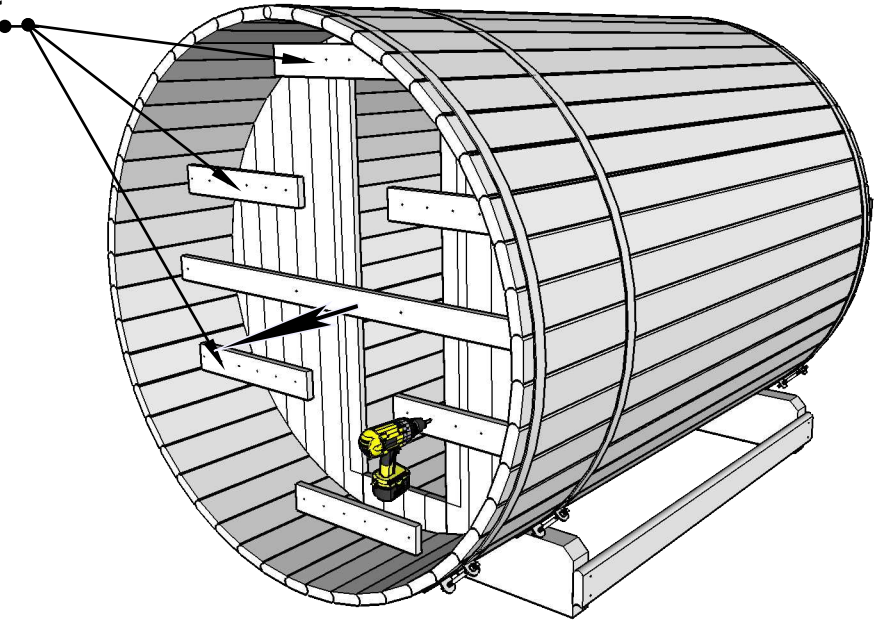

Die gezeigten Bretter bitte entfernen

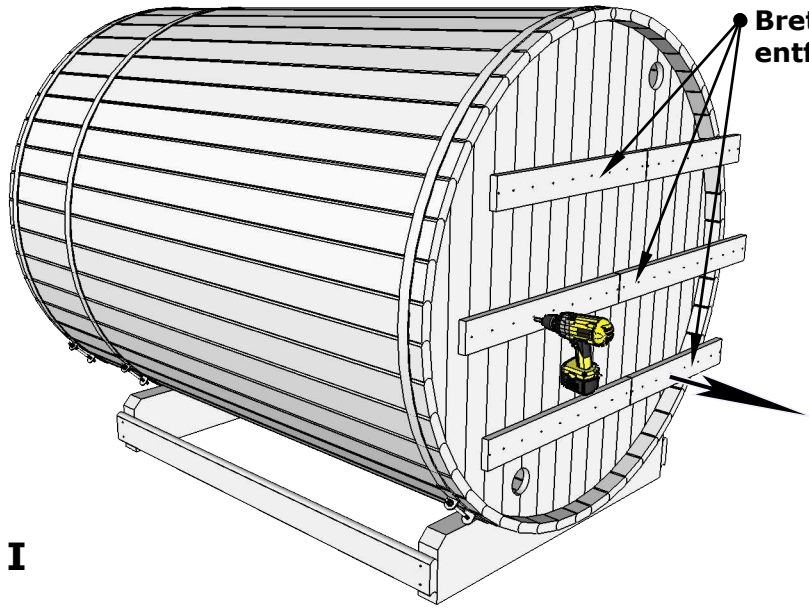

I

Sauna 280, D 200

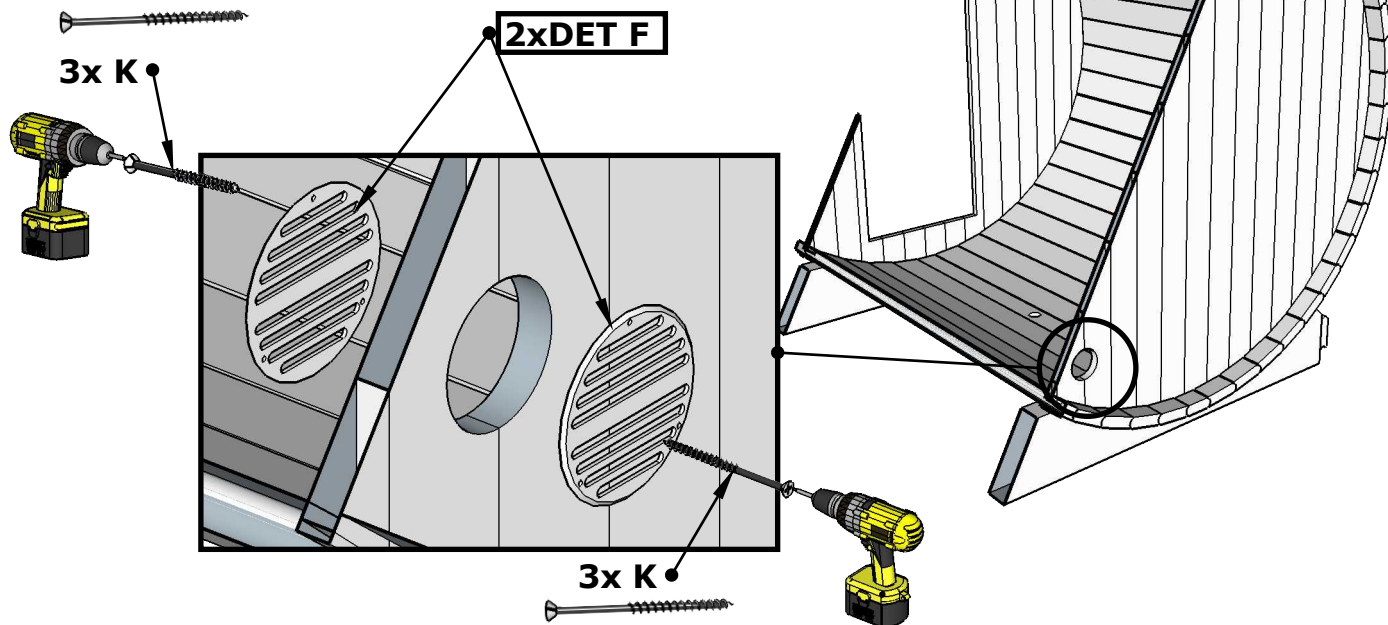
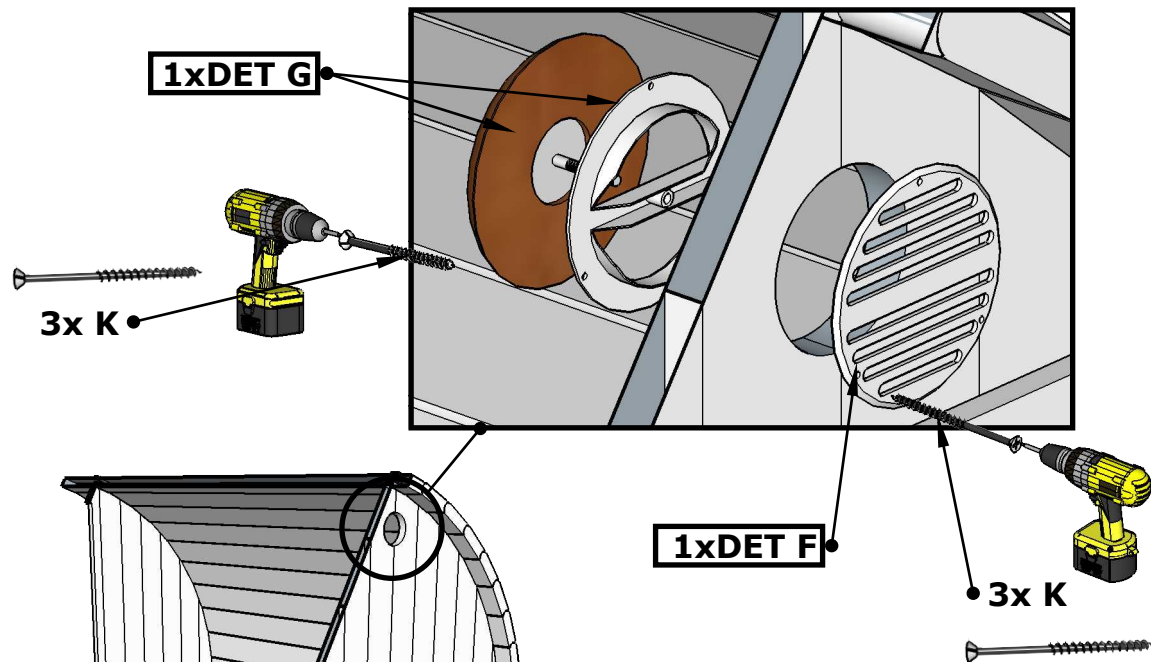
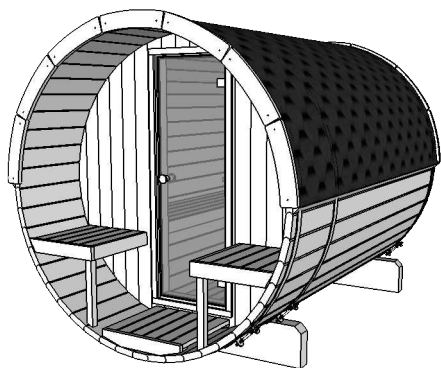

Sauna 280, D 200

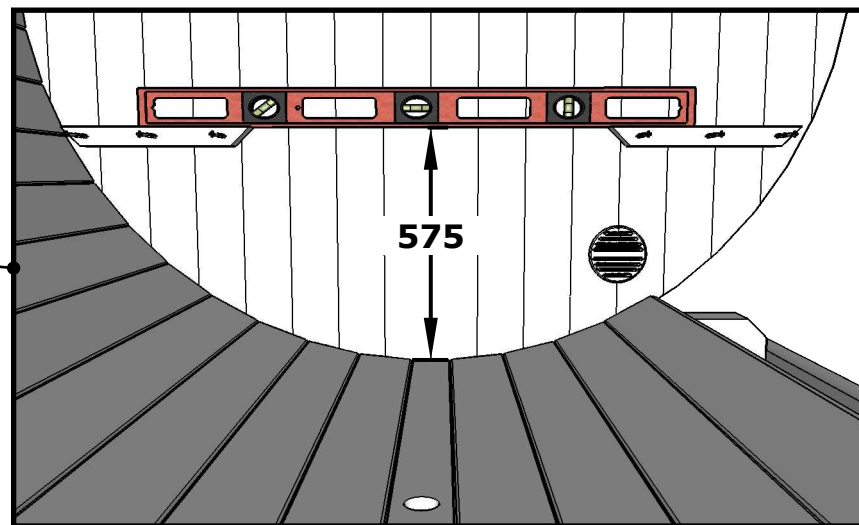
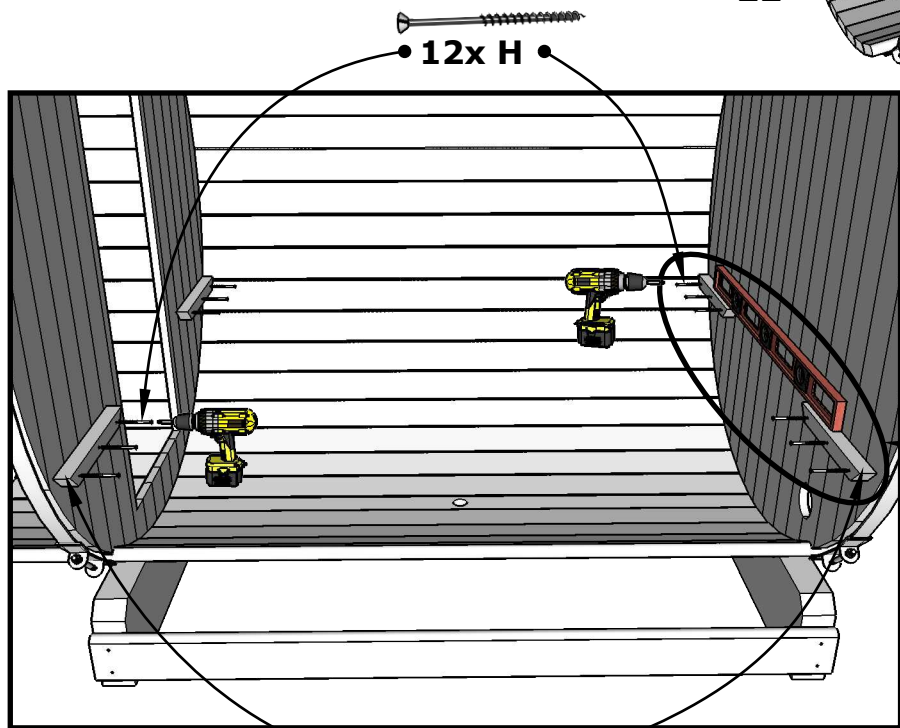
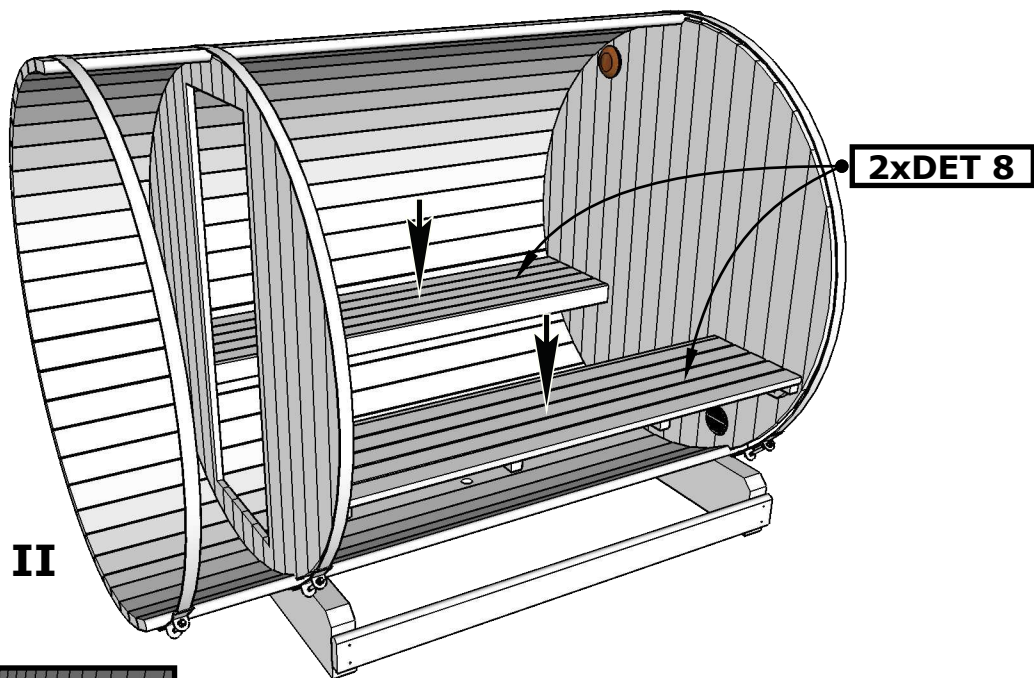
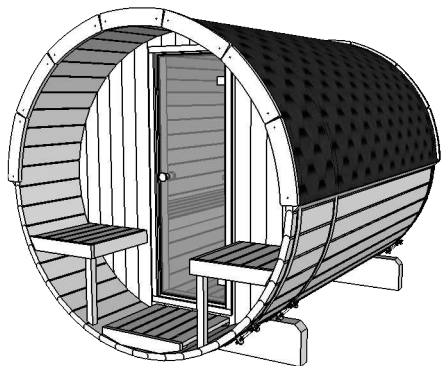

10.

Sauna 280, D 200

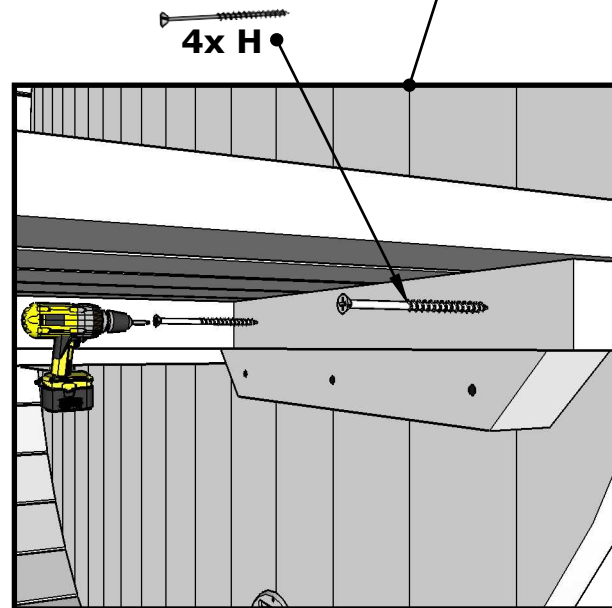
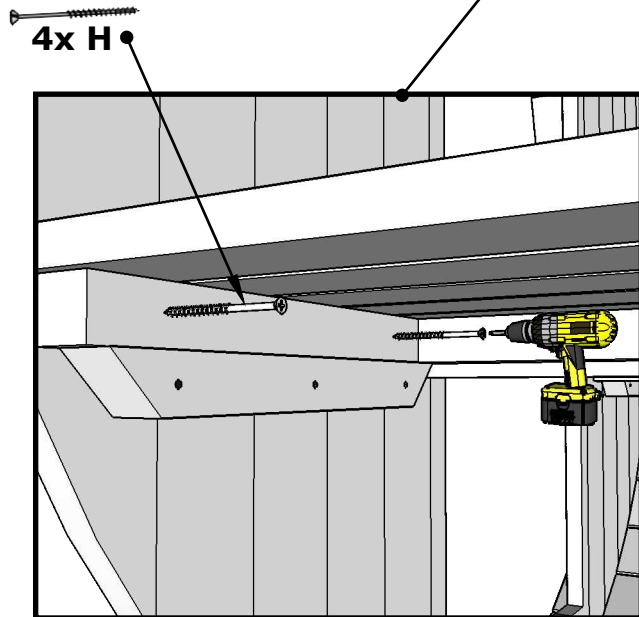
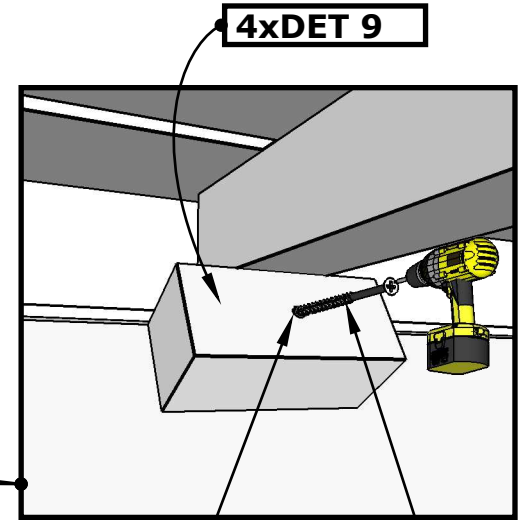
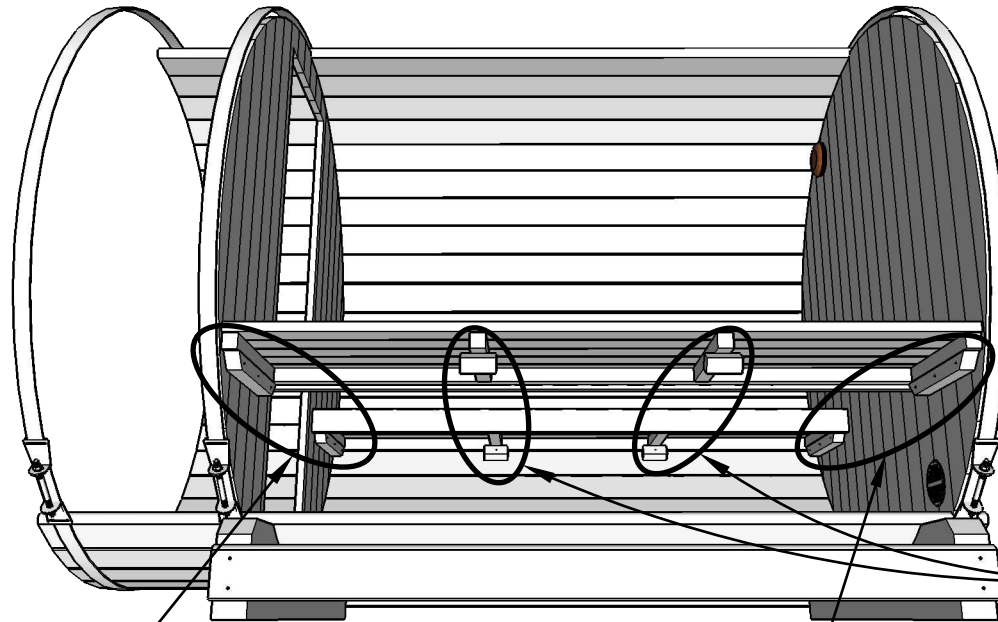
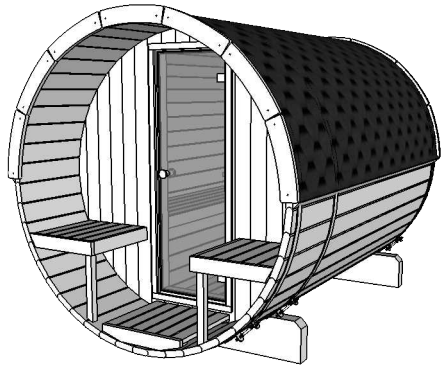

4x H ●

Bitte bohren Sie Ø4mm Löcher vor dem festschrauben

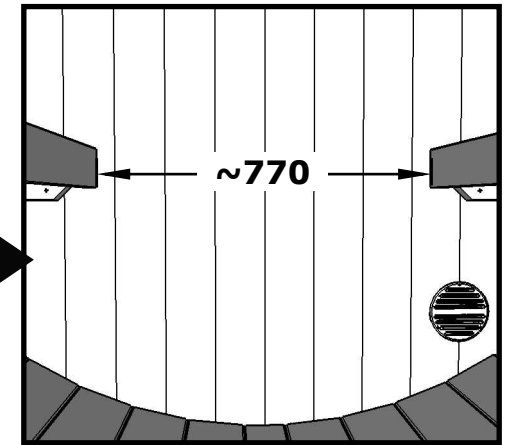

Sauna 280, D 200

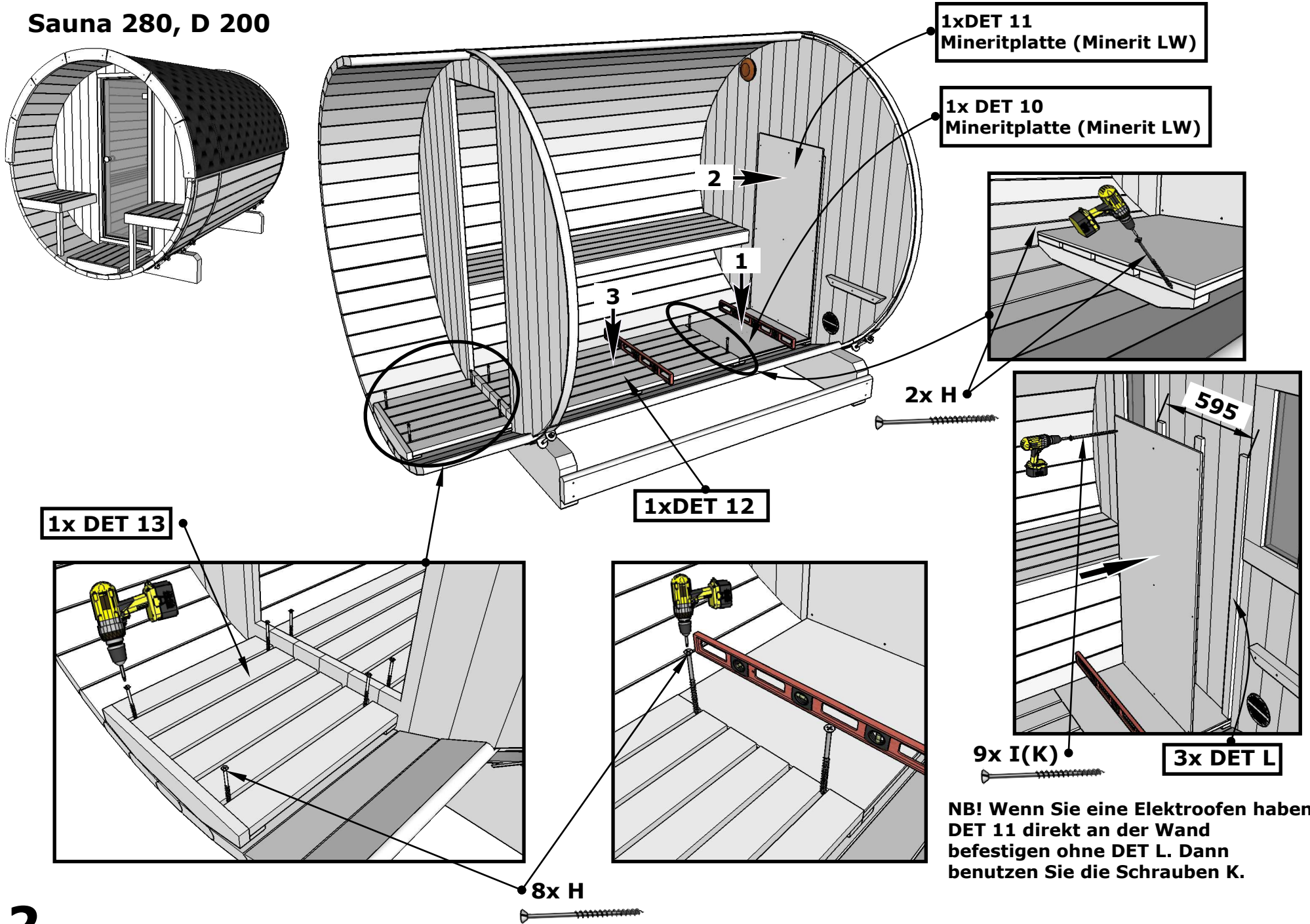

1xDET 11
Mineritplatte (Minerit LW)

1x DET 10
Mineritplatte (Minerit LW)

1x DET 13

1xDET 12

2x H

595

9x I(K)

3x DET L

NB! Wenn Sie eine Elektroofen haben,
DET 11 direkt an der Wand
befestigen ohne DET L. Dann
benutzen Sie die Schrauben K.

8x H

Sauna 280, D 200

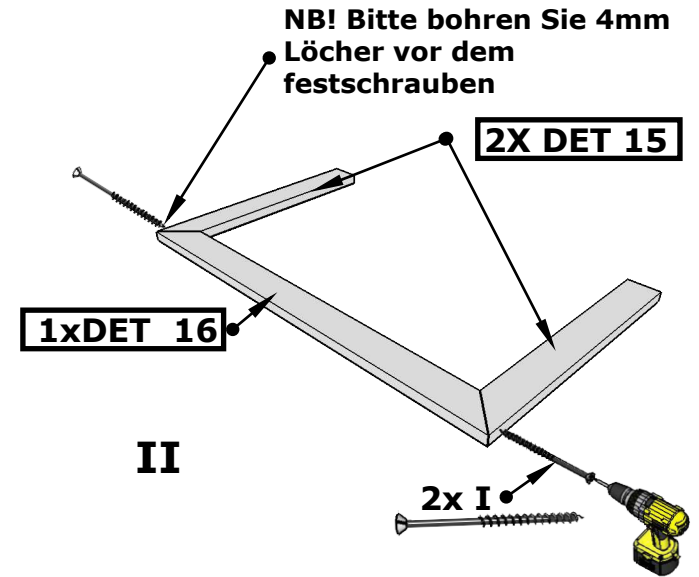
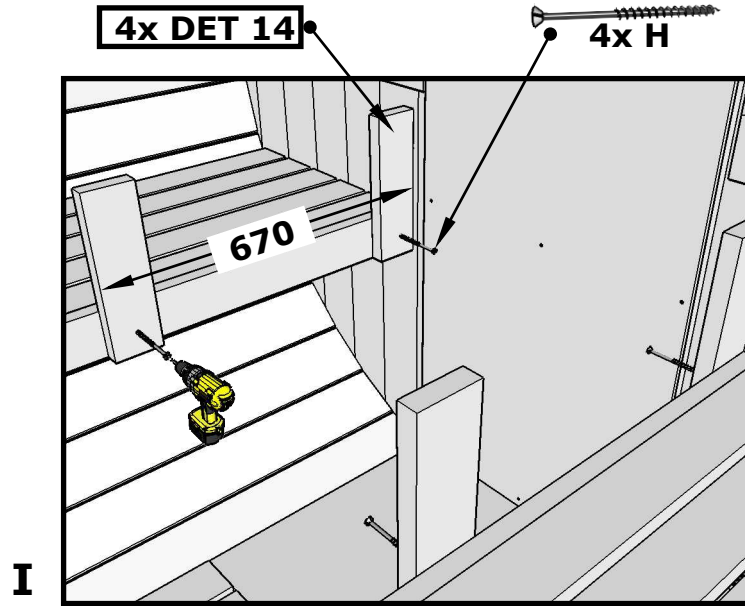
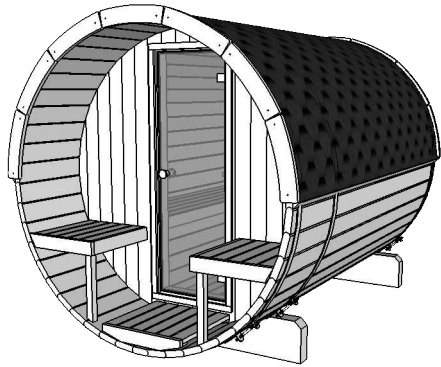

NB: Platz für Sauna Ofen

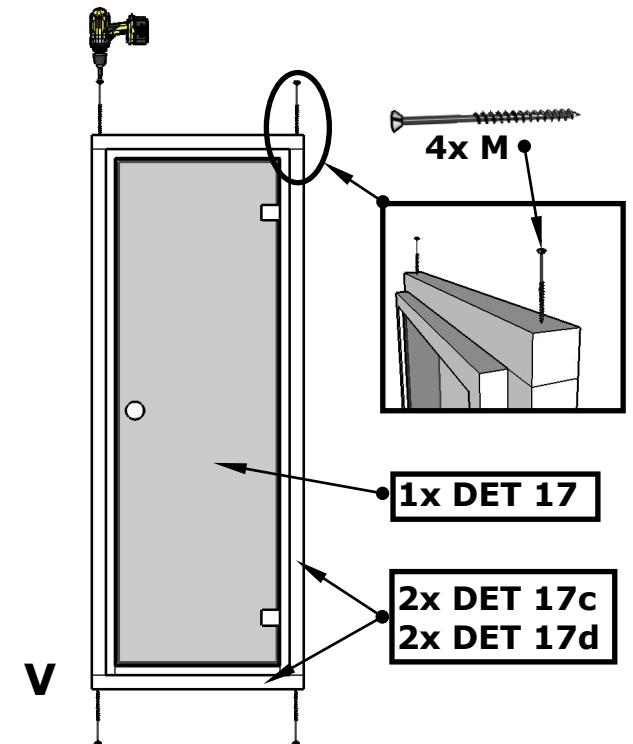
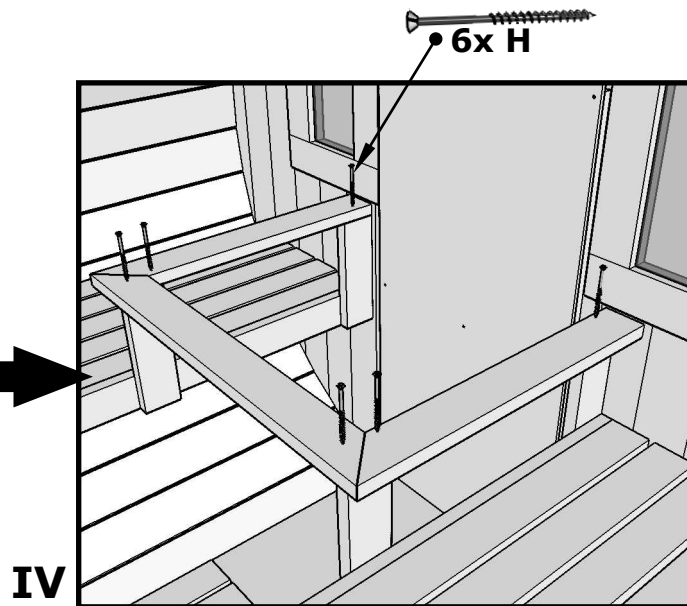
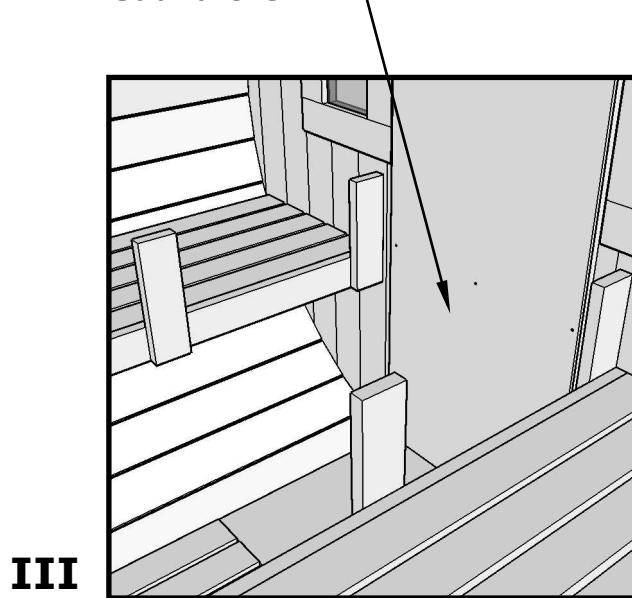

Sauna 280, D 200

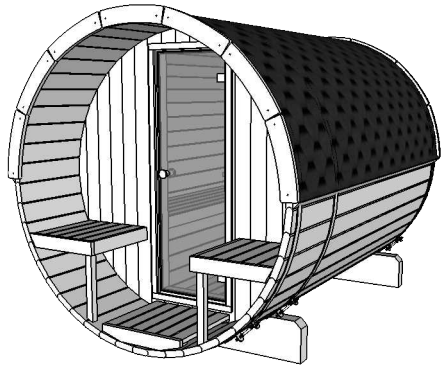

Benutzen Sie eine Wasserwaage bei dem Tür Einbau.

NB! Tür von Innen einbauen!

1x DET 17

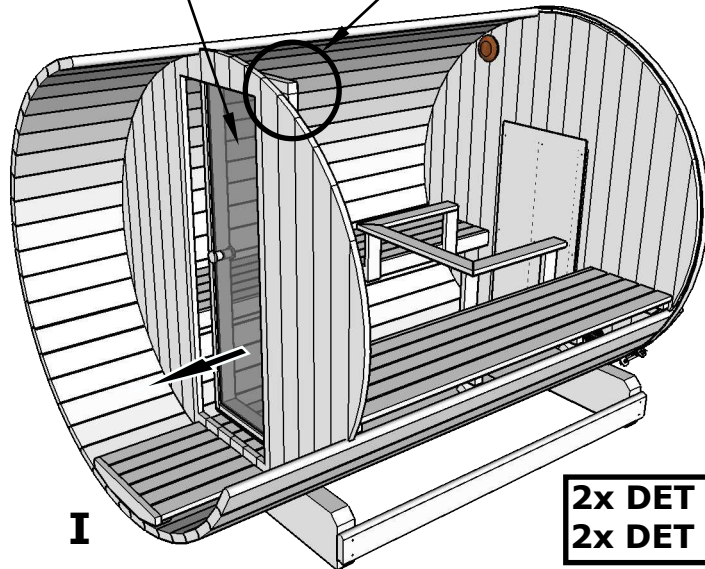

I

2x DET 17a
2x DET 17b

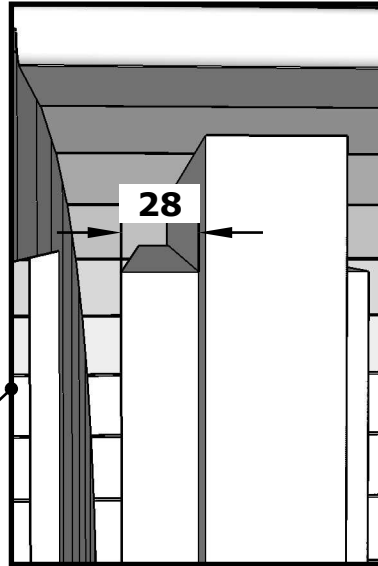

28

Die Schrauben in jedem Brett horizontal festschrauben.

II

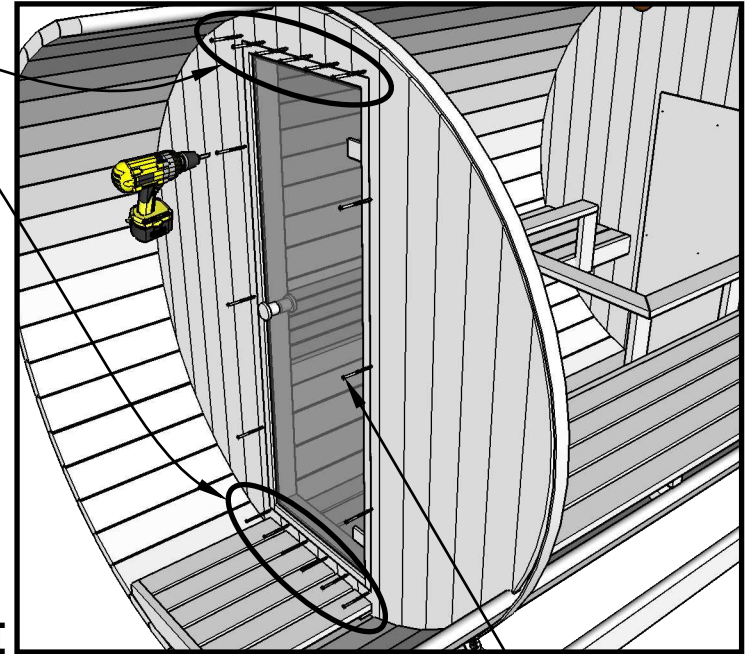

14x J

8x H

18x H

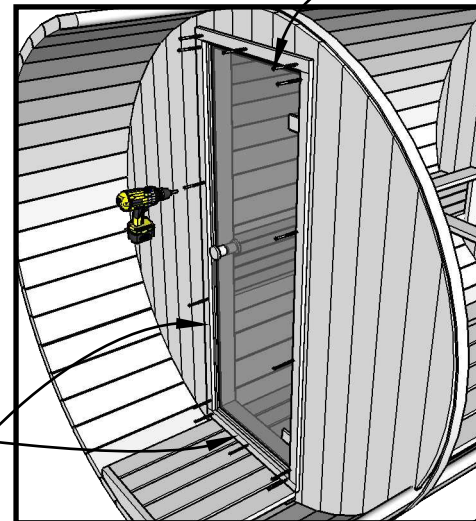

IV

Sauna 280, D 200

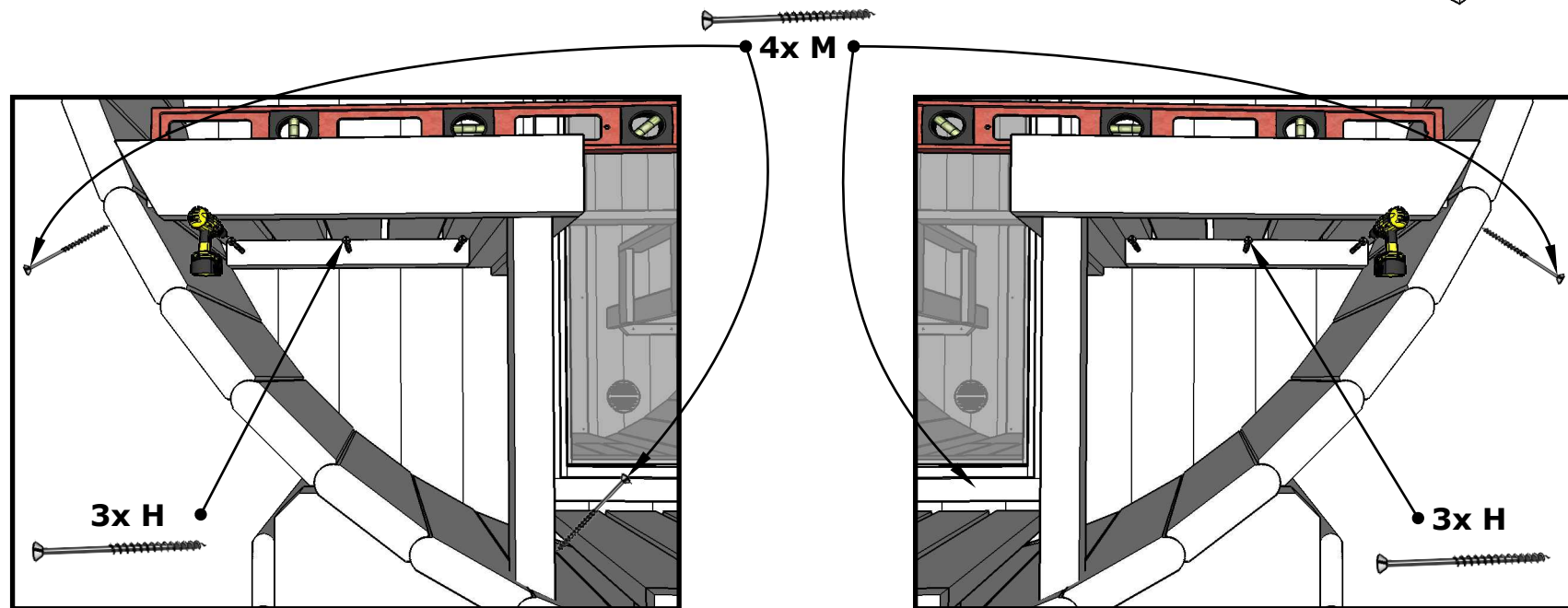
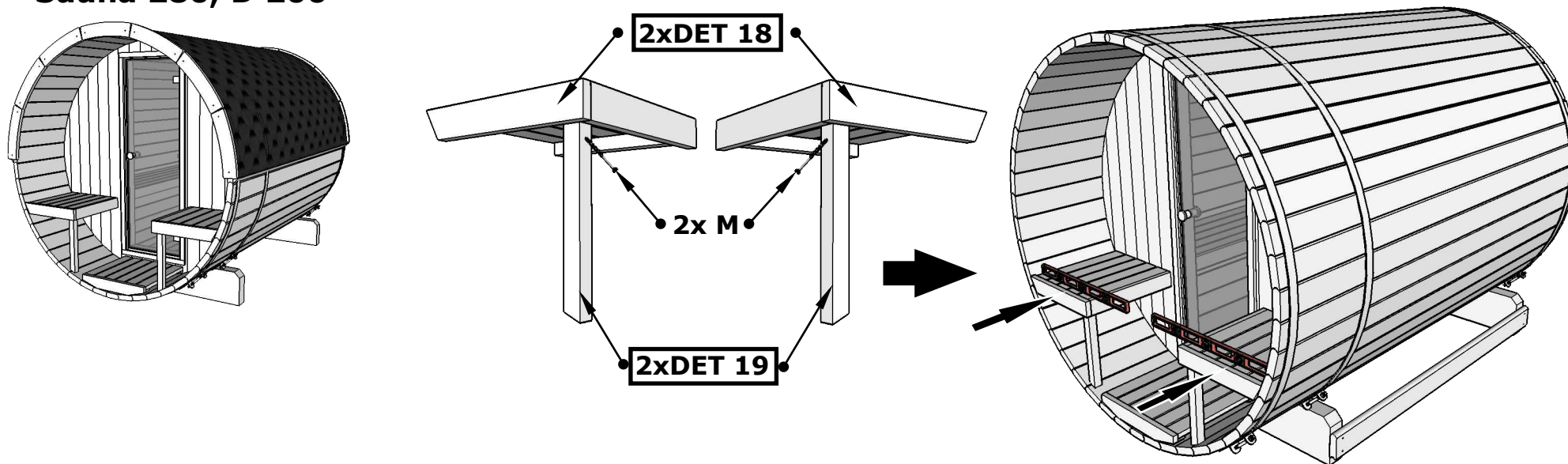

Sauna 280, D 200

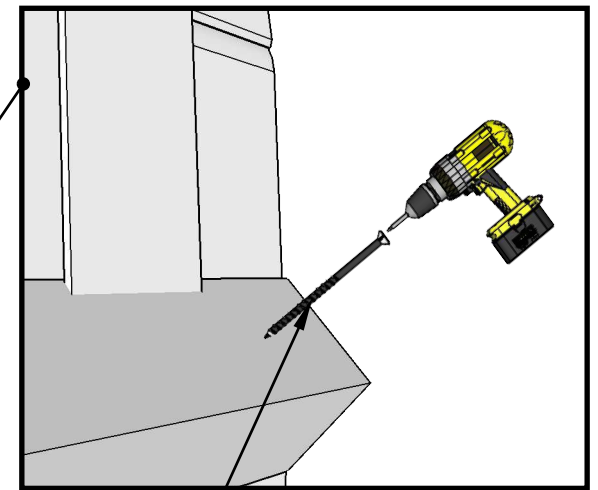
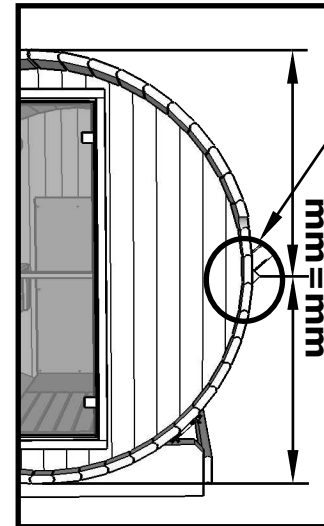
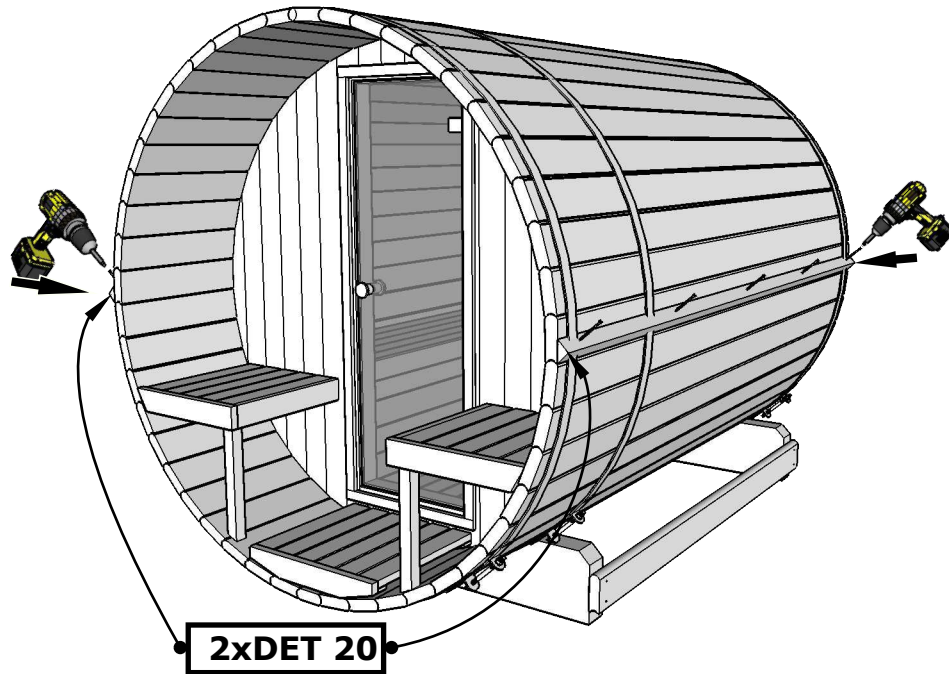
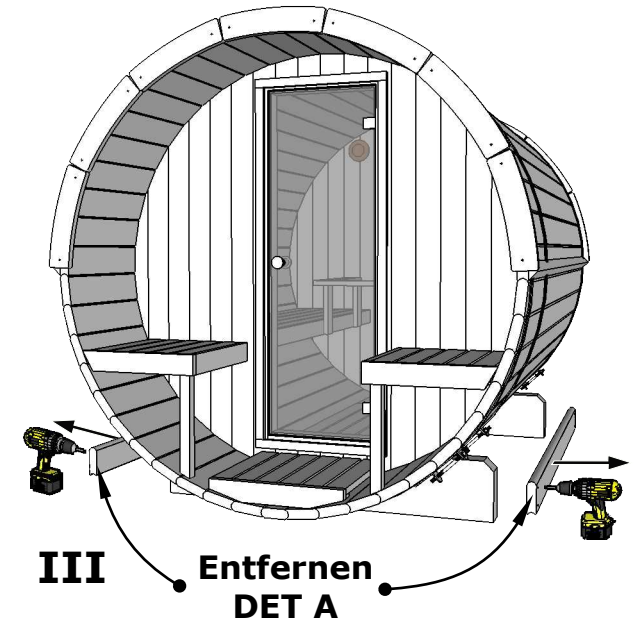
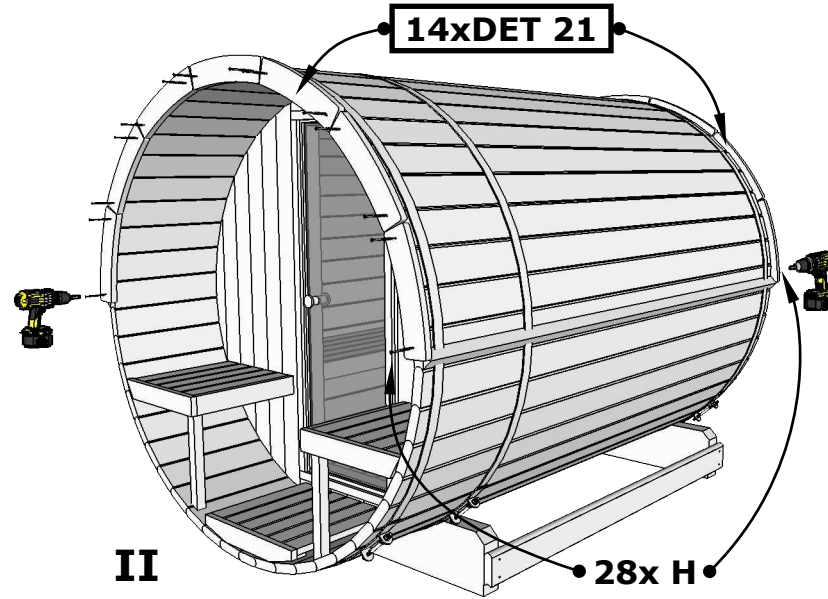
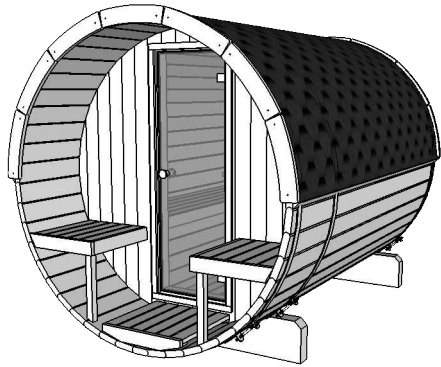

Pflegehinweise „Saunafass“

Vielen Dank das Sie sich für ein komplett montiertes Saunafass entschieden haben.

Der Baustoff Holz ist ein natürlicher Baustoff, welcher Ihnen lange Freude bereiten wird.

Bitte beachten Sie hierzu folgende Pflege und Montagehinweise:

Nach aufstellen des Saunafasses auf ein entsprechend vorbereitetes Fundament, entfernen Sie bitte die seitlichen, unteren Transportbohlen.

In den ersten zwei Jahren muss das Trocknungsverhalten des Holzes genauestens beobachtet werden. Hierzu ist es erforderlich das Saunafass von Zeit zu Zeit nach bzw. zu entspannen.

In den kälteren Jahreszeiten sollte das Fass über die Nachstell-Vorrichtung, entspannt werden. Hierzu lösen Sie die Mutter ca. 4-8 Umdrehungen. (Sollte die Tür klemmen, dann klopfen Sie die Außenbohlen mittels eines Hammers und einem Holzstück vorsichtig nach außen)

In der wärmeren Jahreszeit sollte die Sauna gespannt werden. Hierzu ziehen Sie die Muttern leicht an (Achtung, bitte spannen Sie zwischen den Holztürrahmen ein Holzstück in der Mitte, damit dieser nicht durch das anziehen der Muttern eingedrückt wird)

Die Außenangebrachten runden Blenden müssen an den Stößen einen Spielraum von ca. 5 mm aufweisen. Bitte kontrollieren Sie dieses bei dem Nachspannen. Es kann erforderlich sein das die Blenden bei einem extremen Spannvorgang gelöst werden müssen.

Sollte die Tür klemmen, müssten Sie Ihr Fass über die Spannvorrichtung entspannen.

Das Holz im Außenbereich sollte von Jahr zu Jahr je nach Verwitterung mittels einer Holzschutzlasur aufgefrischt/gestrichen werden.

Der Innenraum bleibt unbehandelt.

Wir empfehlen den Innenraum, je nach Gebrauch, zu desinfizieren.

Legen Sie immer Handtücher auf die Saunaliegen bevor Sie saunieren.

Wir empfehlen nach dem Gebrauch immer einen gefüllten Eimer mit Wasser in die Sauna zu stellen, damit immer eine gewisse Luftfeuchtigkeit im Innenraum besteht.

Care instructions „Sauna barrel“

Thank you very much for purchasing our completely assembled sauna barrel. The building material wood is a natural product which will serve you for a long time. Please consider the following maintenance and assembly instruction:

Please remove the lateral and bottom transport boards after placing the sauna barrel on the prepared foundation.

It's very important to observe the drying behavior during the first two years. It is necessary to loosen or retighten the sauna barrel from time to time.

During the winter month you should loosen up the sauna barrel with the adjuster. Loosen the nut 4-8 revolutions. If the door jam, carefully knock the outside planks with the help of a hammer and a piece of wood outward.

During the summer month you should retighten the sauna barrel. (Attention: tighten nuts carefully and place a piece of wood in the middle of the wooden doorframe to avoid crushes).

The exterior mounted round panels must have a room of 5mm where they meet. Please control this during retighten the sauna barrel. It may be necessary to dismantle the panels due to extreme clamping.

If the door jam, loosen up the sauna barrel with the adjuster.

The outdoor wood should be painted from year to year according to weathering with a protective wood finish.

The interior space remains untreated.

We recommend to disinfect the interior, depending on use.

Always use towels during taking the sauna.

We recommend to place a bucket filled with water into the sauna after use. This provides a certain amount of humidity.

Notice d'entretien «Sauna tonneau»

Merci d'avoir choisi un sauna tonneau entièrement monté de Finnhaus.

Le bois est un matériau de construction naturel qui vous apportera toute satisfaction pendant longtemps.

Pour cela, veuillez suivre les indications d'entretien et de montage ci-après :

- Après la pose du sauna tonneau sur des fondations appropriées, retirez les madriers de transport latéraux en dessous.
- Les madriers ont pu être déplacés au cours du transport. Pour éviter la formation de fissures, détachez les anneaux de tension, remplacez les madriers dans la bonne position puis resserez les anneaux de tension. Suivez pour cela la vidéo (Resserrer le sauna tonneau) sur www.finnhaus.de
- Pendant les deux premières années, il faut surveiller précisément le processus de séchage du bois. Pour cela, il est nécessaire de retendre ou détendre le sauna tonneau de temps en temps.
- Pendant les mois d'hiver, il faut détendre le tonneau par le dispositif de réglage. Pour cela, dévissez les boulons d'environ 4-8 tours. (Si la porte coince, tapez délicatement vers l'extérieur sur les madriers extérieurs à l'aide d'un marteau et d'un morceau de bois)
- A la belle saison, il faut tendre le sauna. Pour cela, serrez légèrement les boulons (attention, placez un morceau de bois au milieu du cadre de porte en bois pour empêcher qu'il ne s'enfonce en serrant les boulons). Retirez les bandeaux à l'avant et à l'arrière.
- Les bandeaux ronds placés à l'extérieur doivent présenter un jeu d'environ 5 mm avec les joints. Vérifiez-le en resserrant. Il peut être nécessaire de retirer les bandeaux en cas de processus de tension extrême.
- Si la porte coince, il faut détendre le tonneau par le dispositif de réglage.
- D'une année sur l'autre, en fonction des conditions météorologiques, il faut rafraîchir/peindre le bois à l'aide d'une lasure de protection.
- L'espace intérieur ne se traite pas.
- Selon l'usage, nous recommandons de désinfecter l'intérieur.
- Posez toujours des serviettes sur les banquettes avant votre séance.
- Nous recommandons de toujours placer un seau plein d'eau dans le sauna après utilisation pour qu'il y règne toujours une certaine humidité de l'air à l'intérieur.

Nous vous souhaitons de bien profiter de votre sauna tonneau

L'équipe service clients Finnhaus

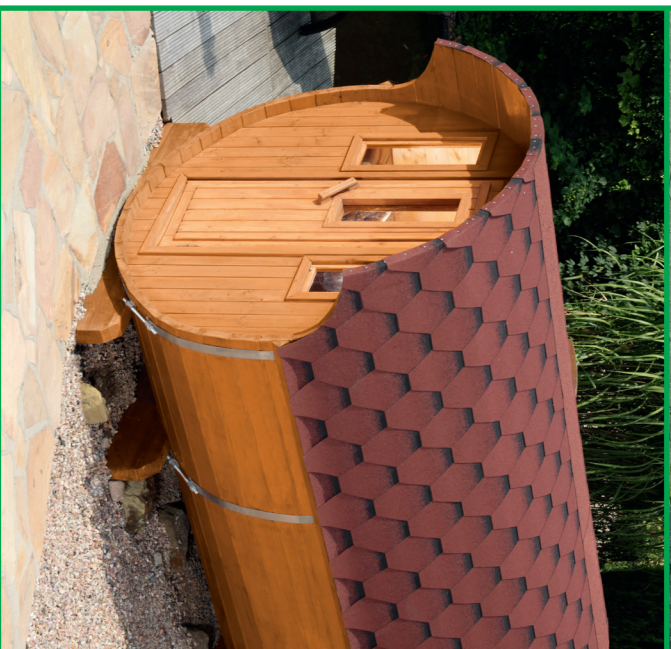

Onderhoudsinstructies „saunavat“

Hartelijk dank dat u gekozen hebt voor een volledig gemonteerd saunavat van Finnhaus.

Het materiaal hout is een natuurlijk materiaal dat u lang vreugde zal schenken.

Neem hiervoor de volgende onderhouds- en montage-instructies in acht:

- Na het opstellen van het saunavat op een overeenkomstig voorbereide fundering verwijderd u de zijdelingse, onderste transportplanken.
- Door het transport zijn de planken eventueel verschoven. Om scheurvorming te voorkomen, maakt u de spanbanden los, brengt u de planken opnieuw in de juiste positie en haalt u de spanbanden opnieuw aan. Neem daarvoor de video (saunavat aanhalen) op www.finnhaus.de Video's in acht.
- Tijdens de eerste twee jaren moet het droogproces van het hout heel precies geobserveerd worden. Hiervoor is het noodzakelijk om het saunavat af en toe aan resp. te ontspannen.
- In de koudere periode van het jaar moet het vat via de aanpasinrichting ontspannen worden. Draai de moeren hiervoor ong. 4-8 omwentelingen los. (Indien de deur klemt, klop dan de buitenste planken met een hamer en een stuk hout voorzichtig naar buiten)
- Tijdens de warmere periode van het jaar moet de sauna moet de sauna gespannen worden.
Haal de moeren hiervoor licht aan (opgelet, span tussen het frame van de houten deur een stuk hout in het midden zodat dit niet door het aanhalen van de moeren wordt ingedrukt). Verwijder de stroken vooraan en achteraan.
- De ronde stroken voor buitengebruik moeten aan de stootkanten een speling van ong. 5 mm hebben. Controleer dit bij het aanspannen. Het kan nodig zijn om de stroken bij een extreme spanprocedure los te maken.
- Als de deur klemt, moet u uw vat via de spaninstallatie ontspannen.
- Het hout in open lucht moet jaar na jaar afhankelijk van verwerking met een houtbeschermingsglazuur opgefrist/ingestroken worden.
- De binnenruimte blijft onbehandeld.
- We raden aan om de binnenruimte, afhankelijk van het gebruik, te desinfecteren.
- Leg altijd handdoeken op de saunabedden voor u de sauna gebruikt.
- We raden aan om na gebruik altijd een gevulde emmer met water in de sauna te plaatsen zodat er altijd een bepaalde luchtvochtigheid in de binnenruimte is.

We wensen u veel pret met uw saunavat

Uw Finnhaus-serviceteam

