

80459

**Aufbauanleitung****notice de montage****Building Instructions****montagehandleiding****Instrucciones de construcción****Istruzioni per il montaggio****Montážní návod****Service-Hotline: +49 421 38693 33**

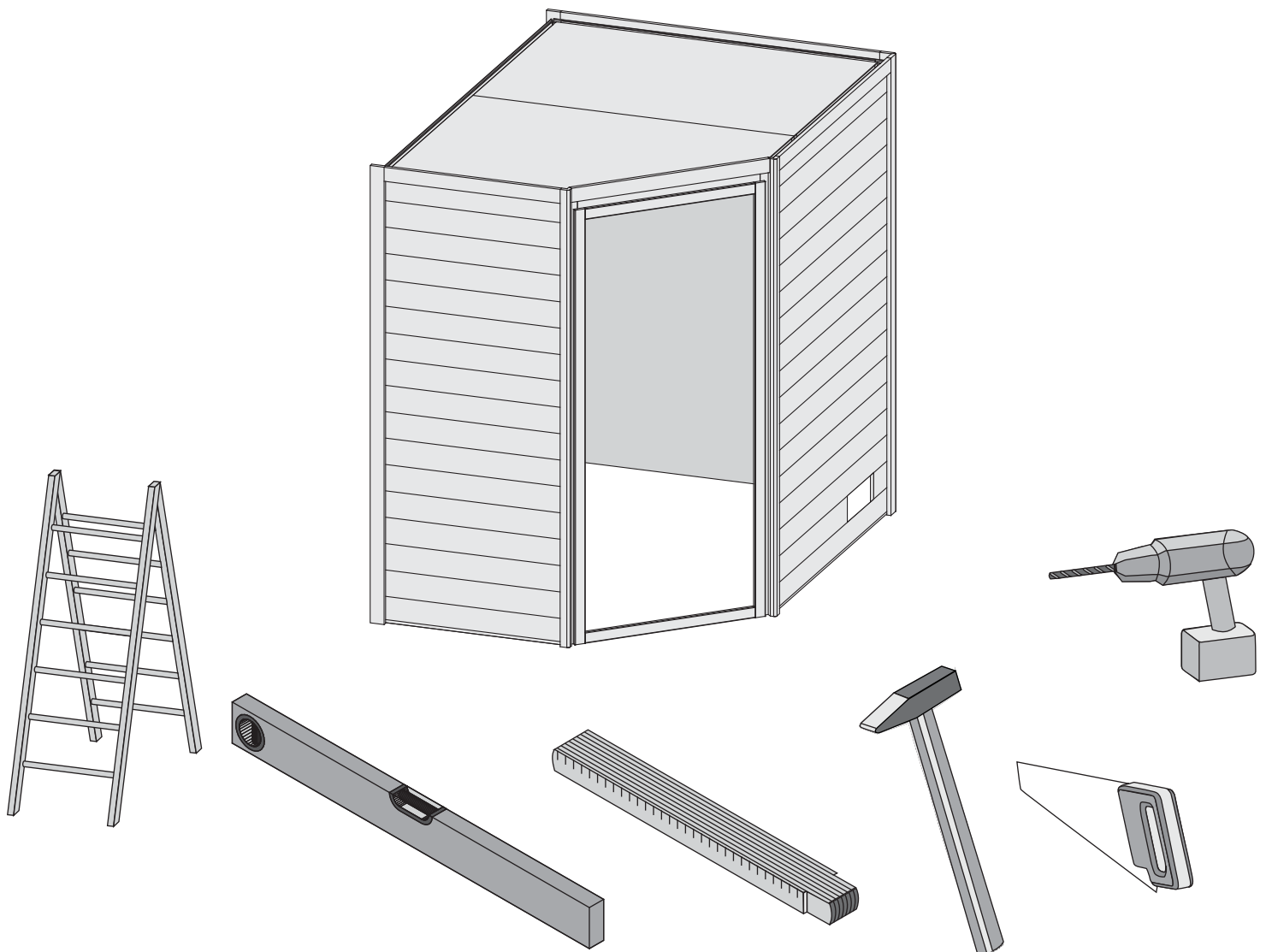

Vergleichen Sie zuerst die Materialliste mit Ihrem Paketinhalt! Bitte haben Sie Verständnis, dass Beanstandungen nur im nicht aufgebauten Zustand bearbeitet werden können!



En primer lugar, compare la lista de material con el contenido del paquete. Rogamos entienda que las reclamaciones sólo pueden ser tramitadas antes de montar el objeto!



Nejprve přezkontrolujte obsah balení podle materiálového listu! Mějte pochopení pro to, že případnou reklamaci se můžeme zabývat pouze tehdy, když díly nebudou smontované! Za pomoci tohoto seznamu můžete jednotlivé díly přiřadit k montážnímu návodu.



Vergelijk eerst de lijst van materialen met de inhoud van uw pakket! Reclamaties kunnen alleen in behandeling worden genomen zolang de onderdelen nog niet zijn gemonteerd!



First compare the list of materials with your package contents! Please understand that complaints can be processed in the non-built status only!



Commencez par comparer la liste du matériel avec le contenu de votre paquet! Sachez que nous traitons uniquement les réclamations concernant le matériel à l'état non monté!



Confrontate questa distinta materiali prima con il contenuto del pacchetto! Vi preghiamo di comprendere che eventuali reclami possono essere accolti solo prima del montaggio!

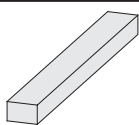
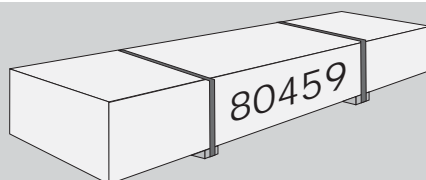

1 x B1	1920 x 20 x 3 mm	ID 20799
2 x B2	1810 x 90 x 16 mm	ID 71513
1 x B3	850 x 58 x 17 mm	ID 48544
7 x B4	2000 x 58 x 17 mm	ID 48541
2 x B5	250 x 45 x 18 mm	ID 26716
2 x B6	550 x 45 x 18 mm	ID 26717
2 x B7	800 x 45 x 18 mm	ID 24796
1 x B8	880 x 45 x 18 mm	ID 21440
2 x B9	1206 x 45 x 18 mm	ID 21439
2 x B10	1809 x 45 x 18 mm	ID 21831
1 x B11	300 x 95 x 18 mm	ID 19130
4 x B12	480 x 95 x 18 mm	ID 20930
4 x B13	565 x 95 x 18 mm	ID 15498
2 x B14	800 x 58 x 28 mm	ID 15493
3 x B15	1916 x 36 x 36 mm	ID 21431
1 x B16	781 x 78 x 38 mm	ID 56718

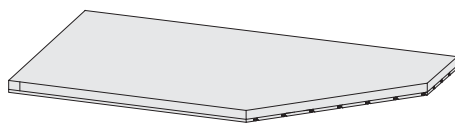

1 x R1 | 1338 x 918 x 55 mm | ID 26585

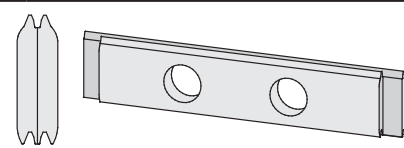

1 x W7 | 1881 x 121 x 38 mm | ID 21864

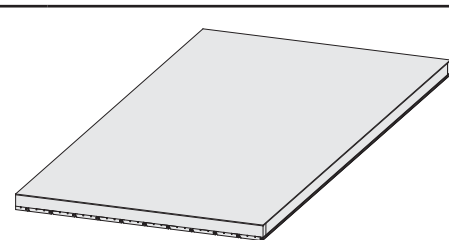

1 x R2 | 1338 x 918 x 55 mm | ID 26575

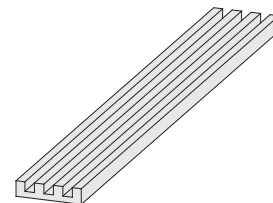

1 x E1 | 1820 x 110 x 26 mm | ID 26480

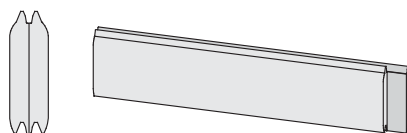

1 x W1 | 803 x 121 x 38 mm | ID 80496

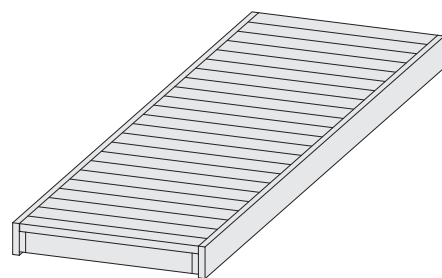

1 x L1 | 1810 x 250 x 90 mm | ID 26576

1 x L2 | 1810 x 550 x 90 mm | ID 43994

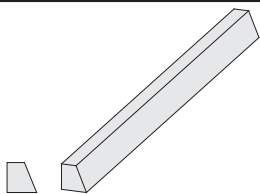

2 x C1	1916 x 36 x 36 mm	ID 21814
2 x C2	1973 x 36 x 36 mm	ID 21825

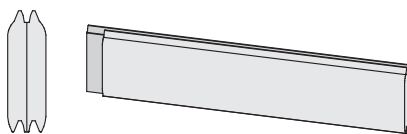

1 x W2 | 200 x 121 x 38 mm | ID 80382

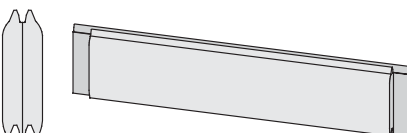

18 x W3 | 777 x 121 x 38 mm | ID 26726

17 x W4 | 1278 x 121 x 38 mm | ID 21430

18 x W5 | 1380 x 121 x 38 mm | ID 26573

17 x W6 | 1881 x 121 x 38 mm | ID 21429

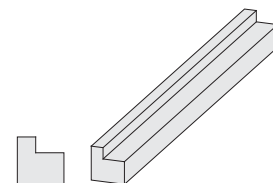

2 x L3 | 250 x 45 x 45 mm | ID 3863

2 x L4 | 555 x 45 x 45 mm | ID 40301

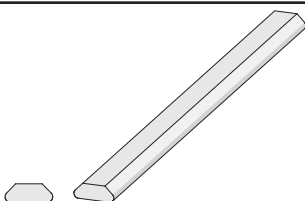

2 x G1	2100 x 45 x 18 mm	ID 80276
--------	-------------------	----------

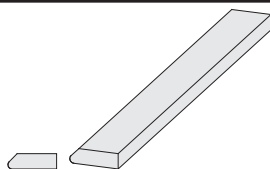

2 x G2	2000 x 58 x 17 mm	ID 48545
--------	-------------------	----------



1 x | ID 14025



- Siehe Türpaket
- Opmerking Door Package
- Note Door Package
- Remarque Package porte
- Nota Paquete Puerta
- Nota Door Package
- Poznámka Door balíček



1 x D1

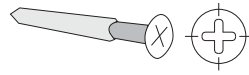

20 x	4 x 30 mm	ID 3686
60 x	4 x 35 mm	ID 3687
350 x	4 x 40 mm	ID 21925
30 x	4 x 50 mm	ID 3688
30 x	4 x 70 mm	ID 3689
25 x	4,5 x 80 mm	ID 9204
20 x	6 x 60 mm	ID 14014
20 x	6 x 80 mm	ID 47558
80 x	6 x 90 mm	ID 26715

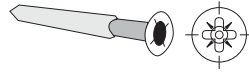





50 x	4,5 x 40 mm	ID 26285
------	-------------	----------

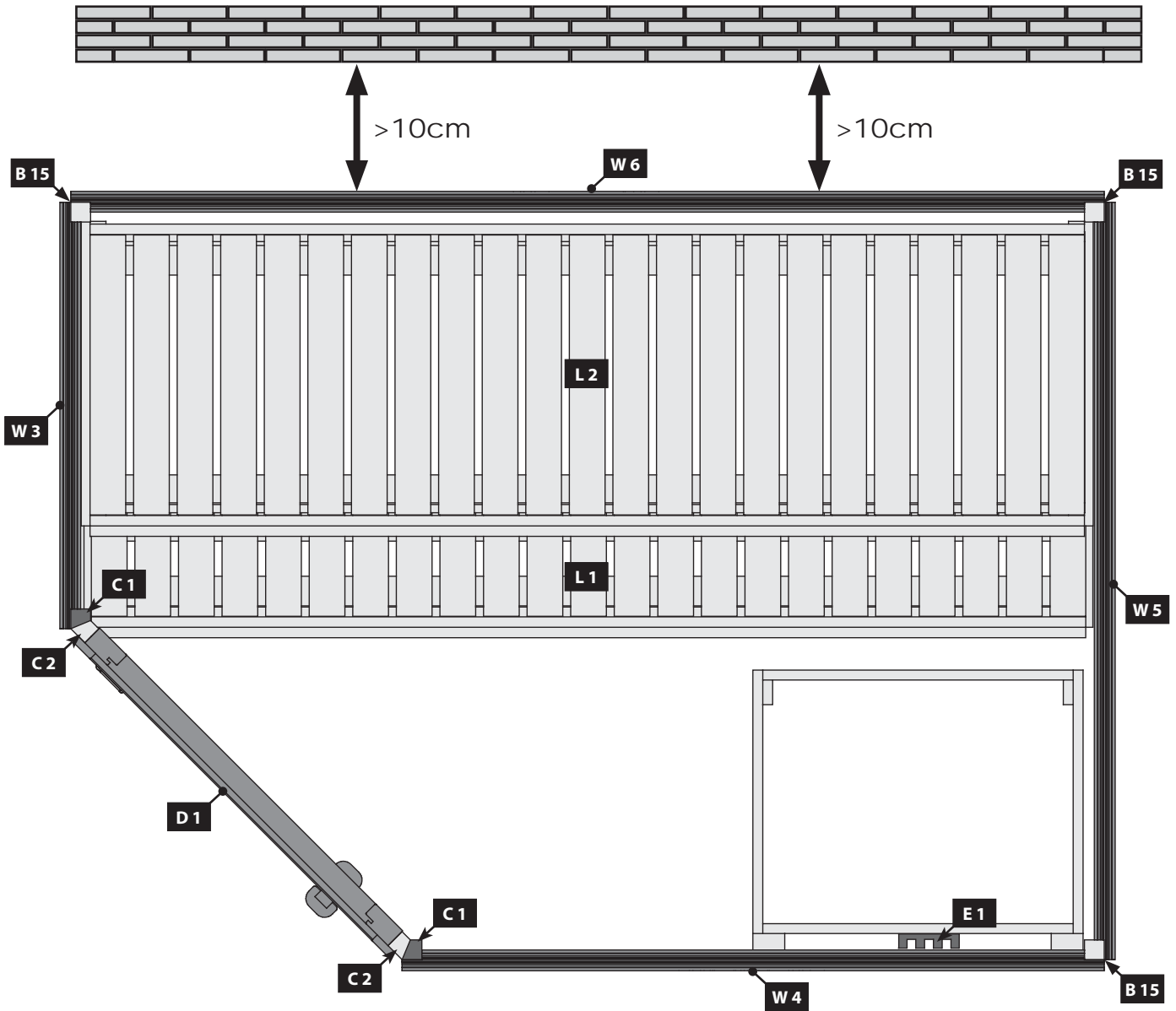

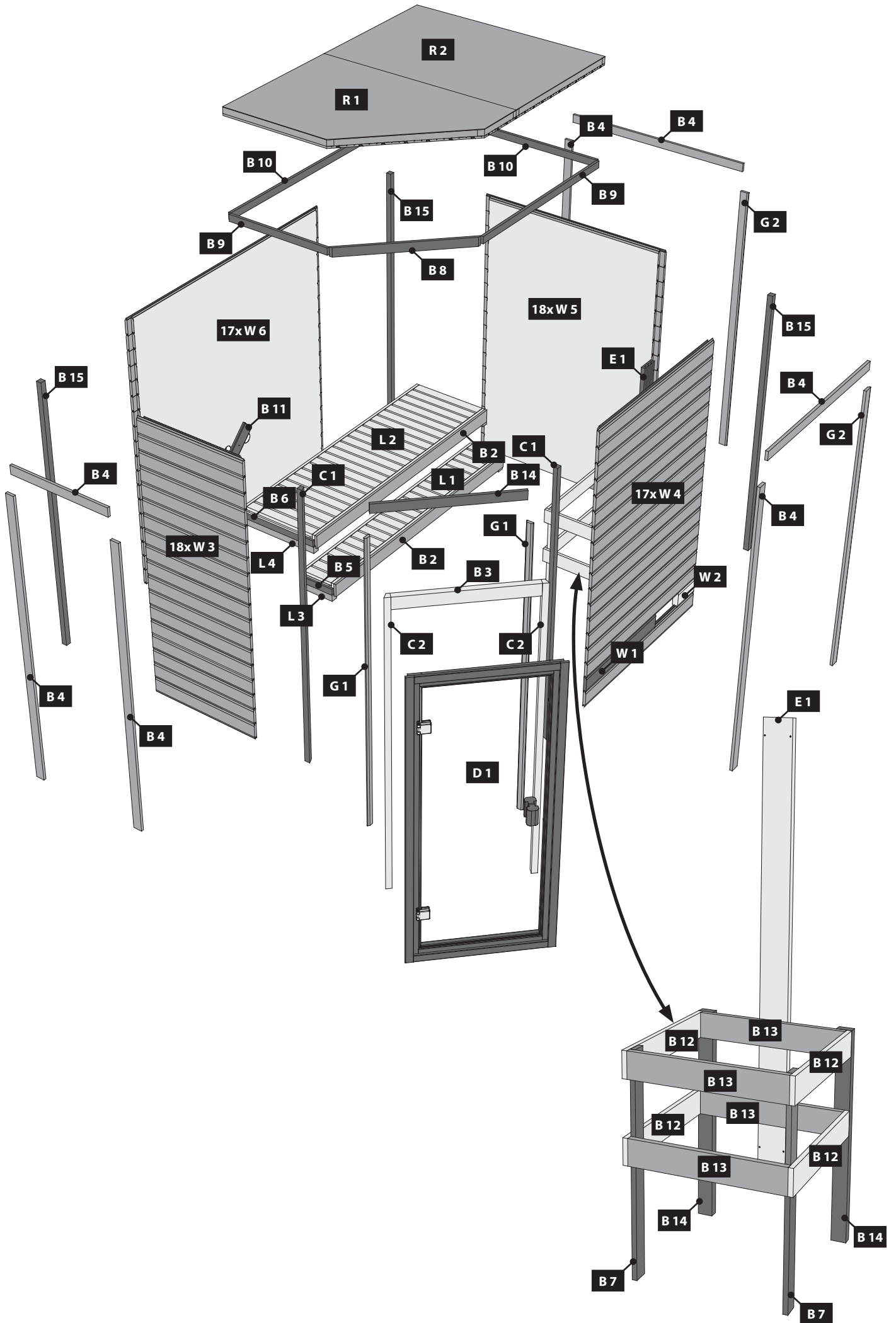



60 x		ID 26116
------	--	----------





 Leim! Achten Sie auf die gleiche Höhe  
 Glue! Look for the same height  
 Colle! Faites attention à la même hauteur

 Lijm! Besteed aandacht aan de dezelfde hoogte  
 Pegamento! Prestar atención a la misma altura  
 Colla! Prestare attenzione alla stessa altezza

 Klíž! Dávejte pozor na stejnou výšku

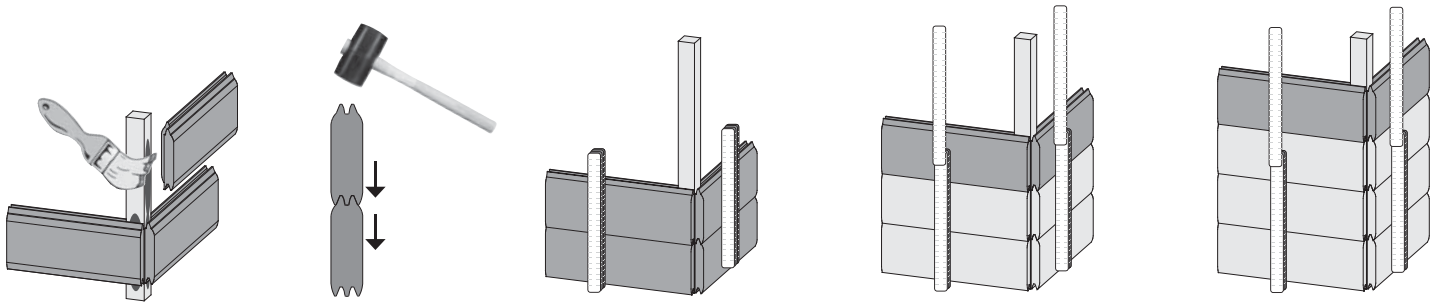

**01**

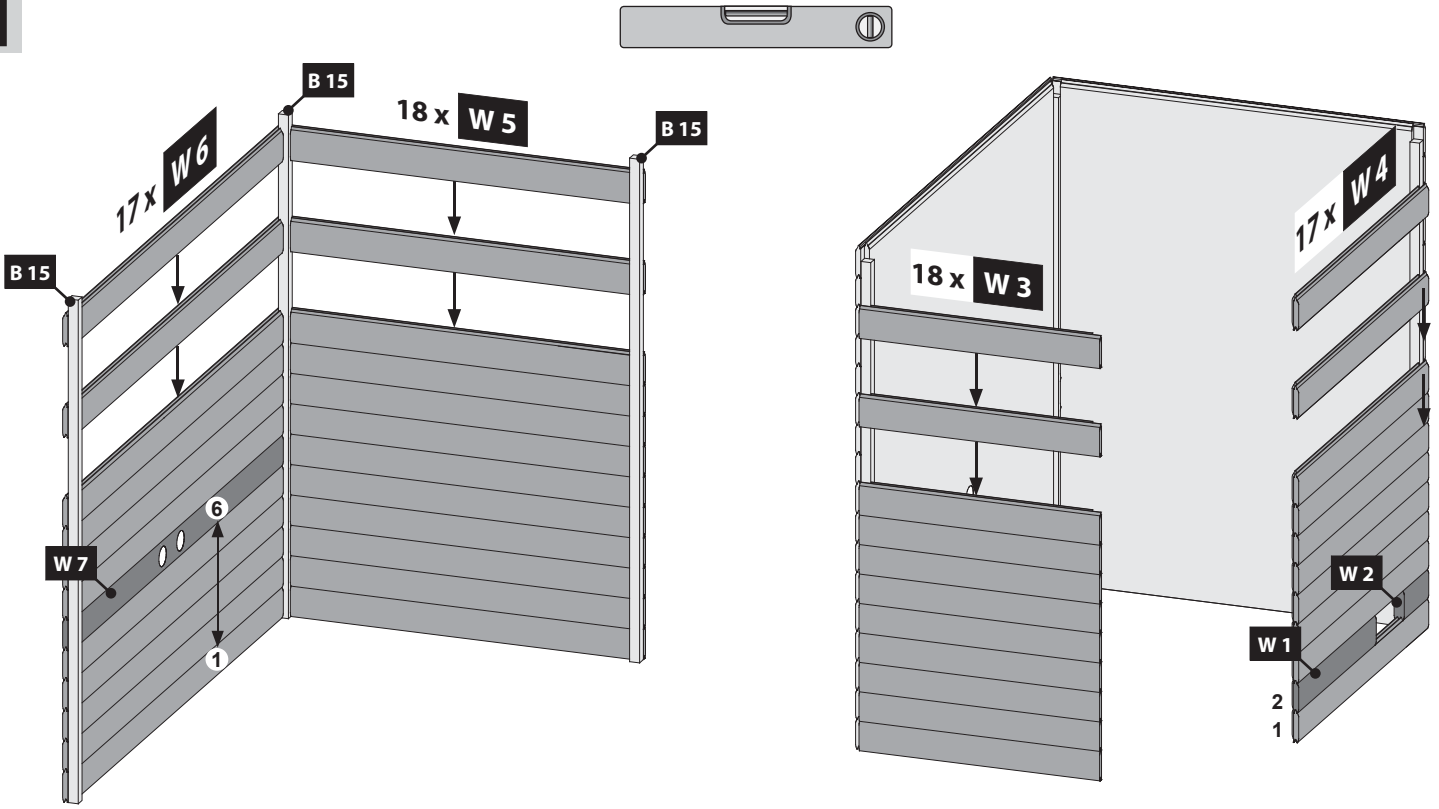

**02**

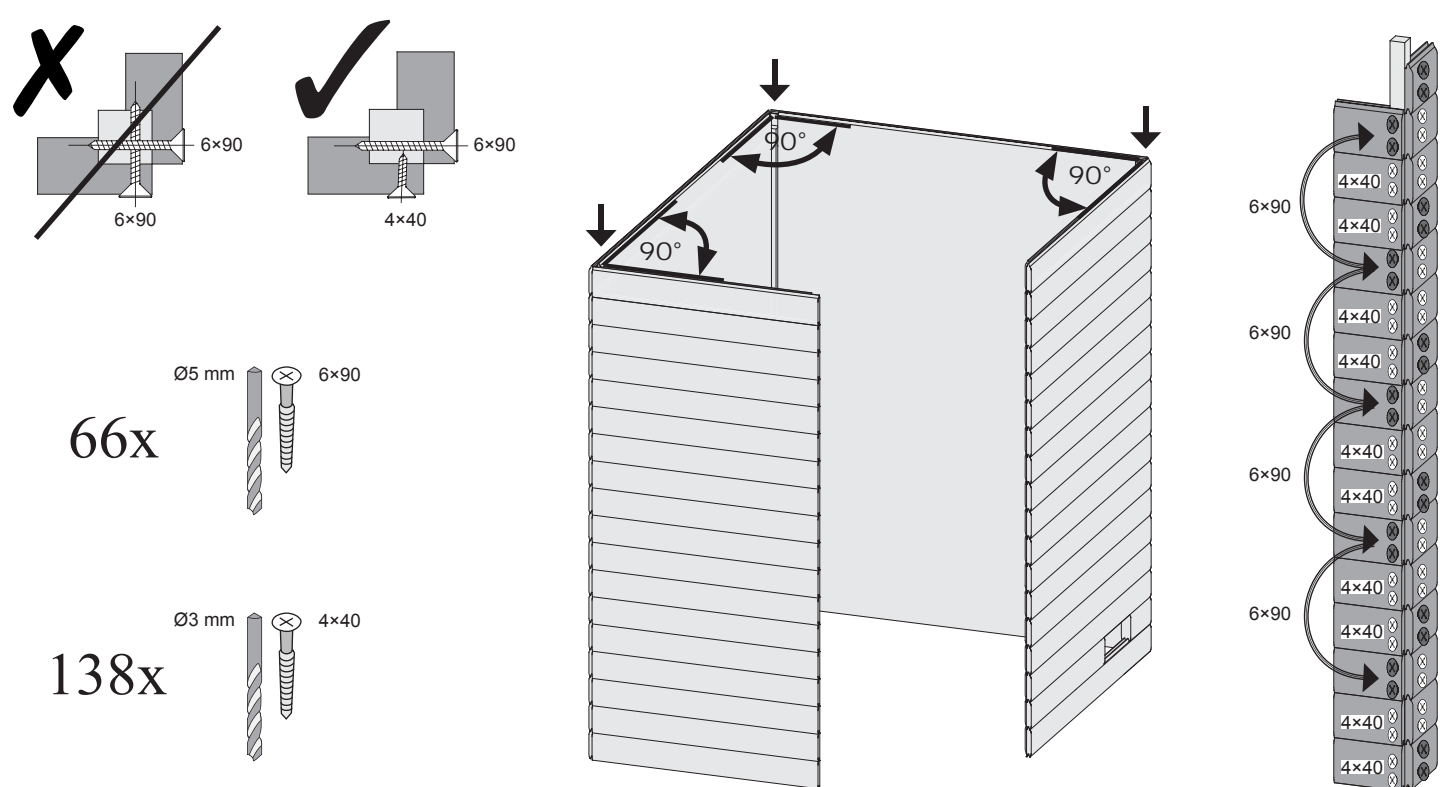

03

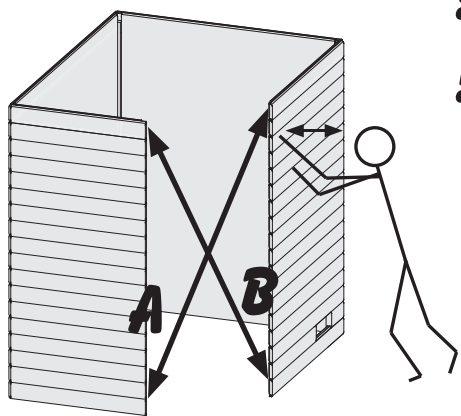

**!!! A=B !!!**  
**!!! C=D !!!**

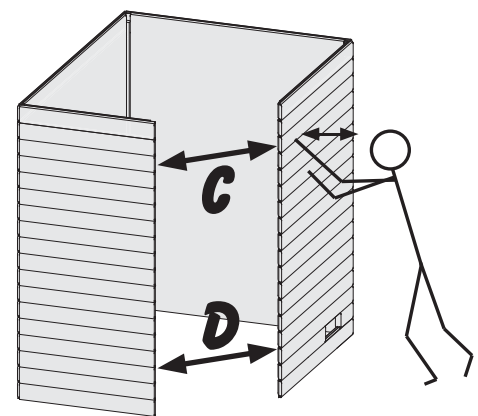

04

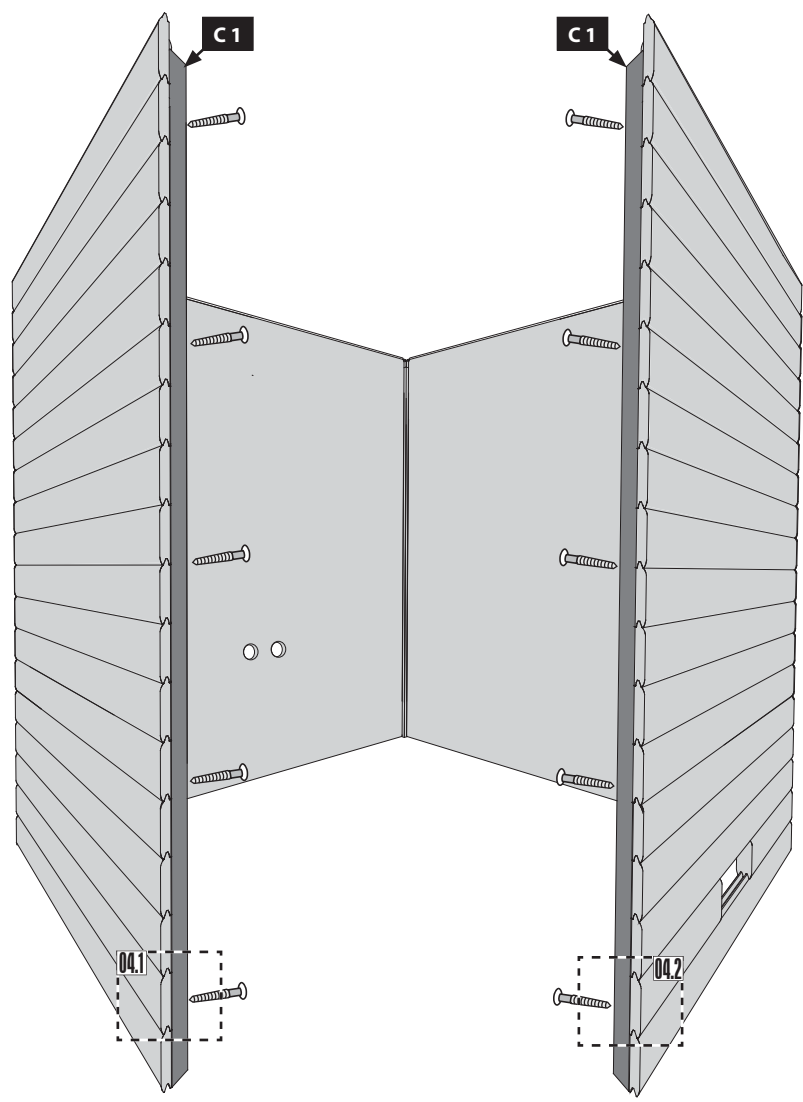

04.1

Ø3mm  4×50

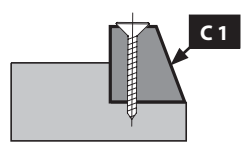
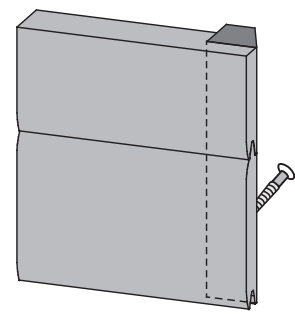

04.2

Ø3mm  4×50

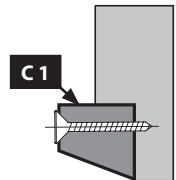
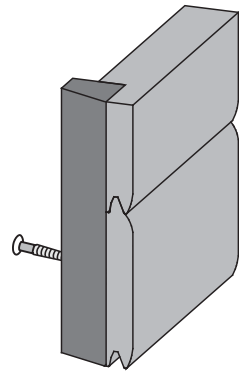

05

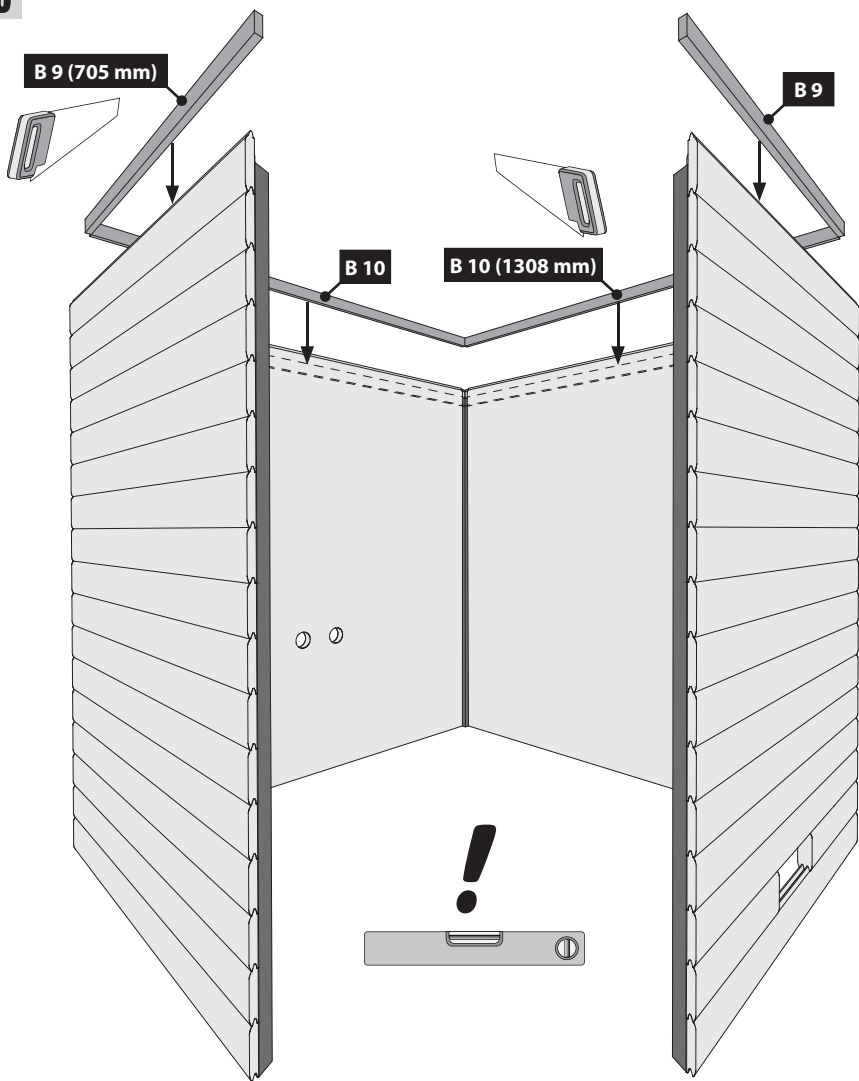

05.1

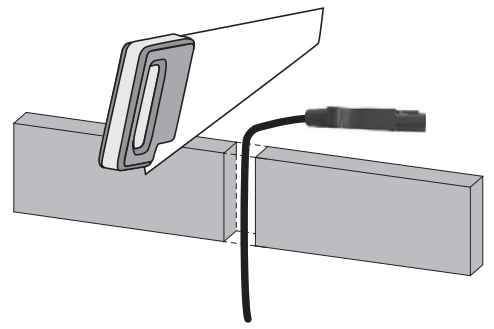

05.2

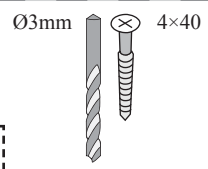

Bündig!  
Affleurement!  
Gelijk!  
Aras!  
Flush!  
Combacia!  
Stejný!

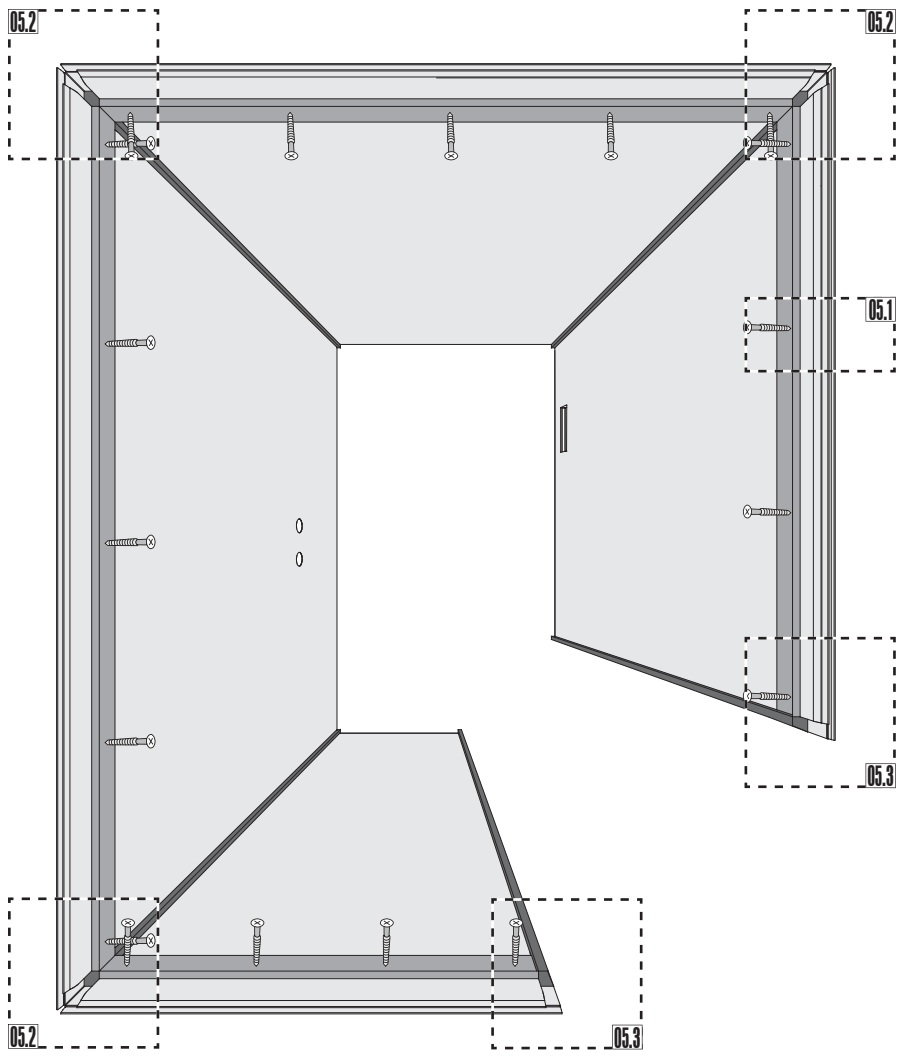
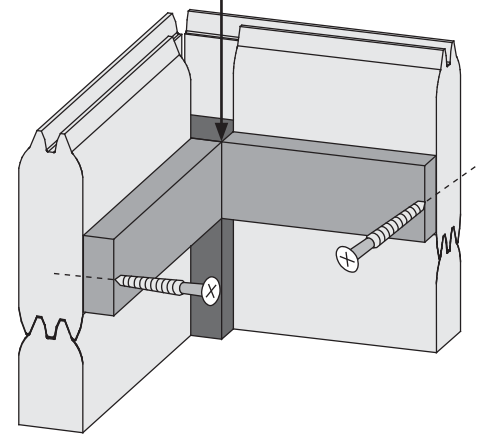

05.3

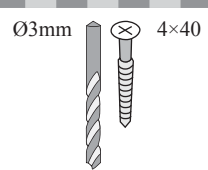

Bündig!  
Affleurement!  
Gelijk!  
Aras!  
Flush!  
Combacia!  
Stejný!

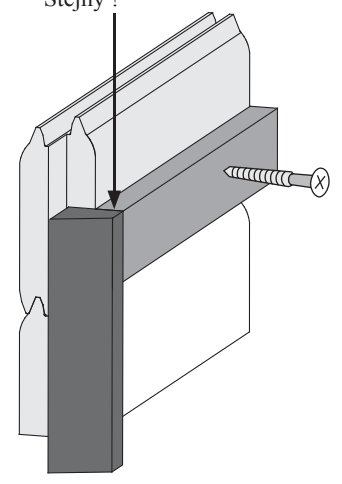

06

Ø3mm 4×50

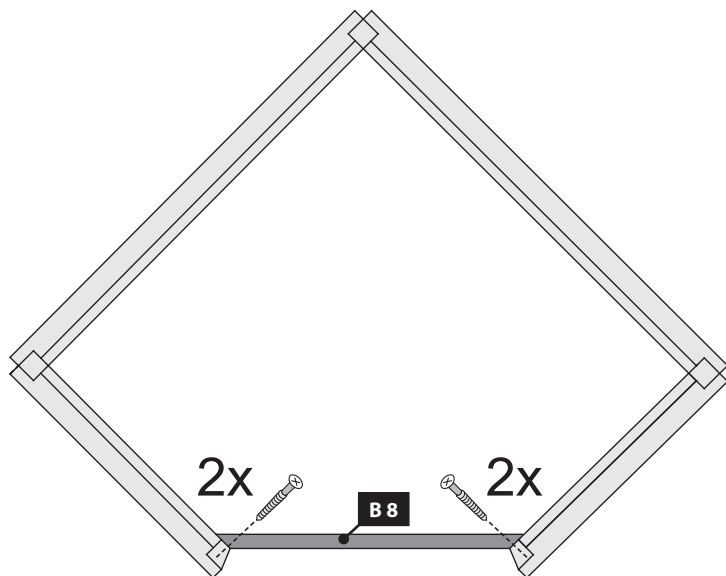
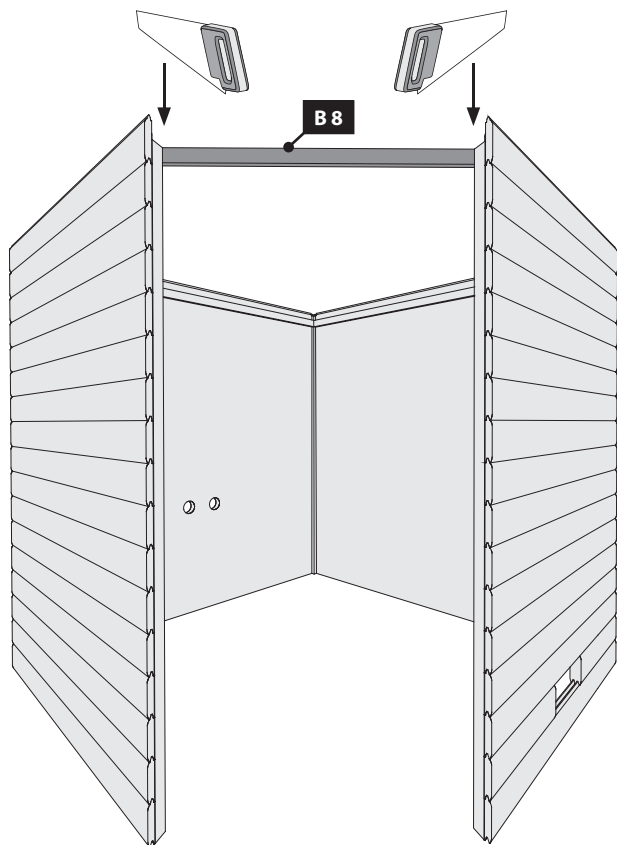



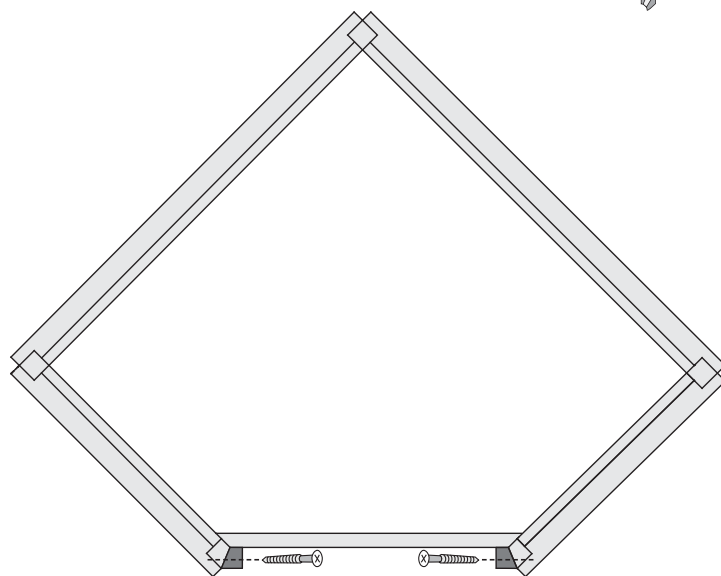
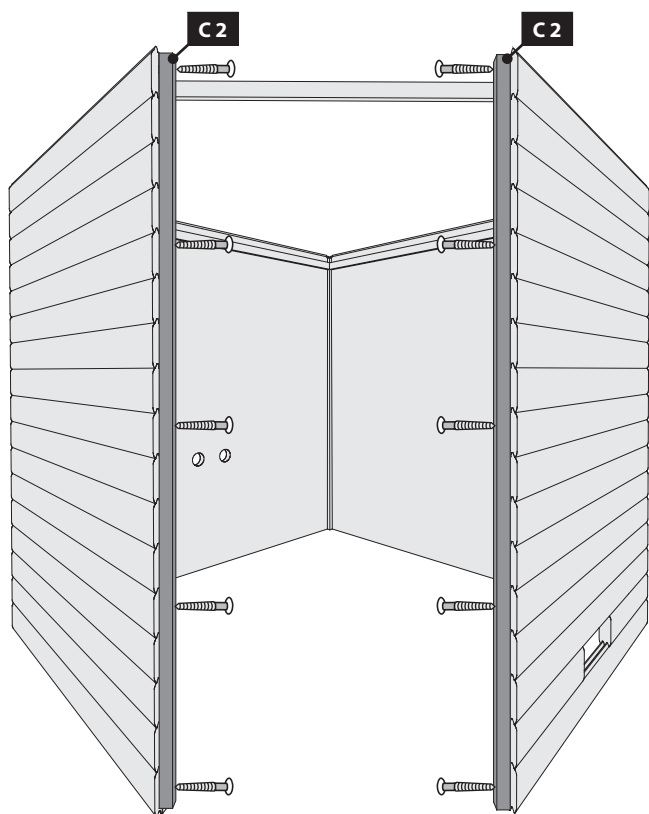

07

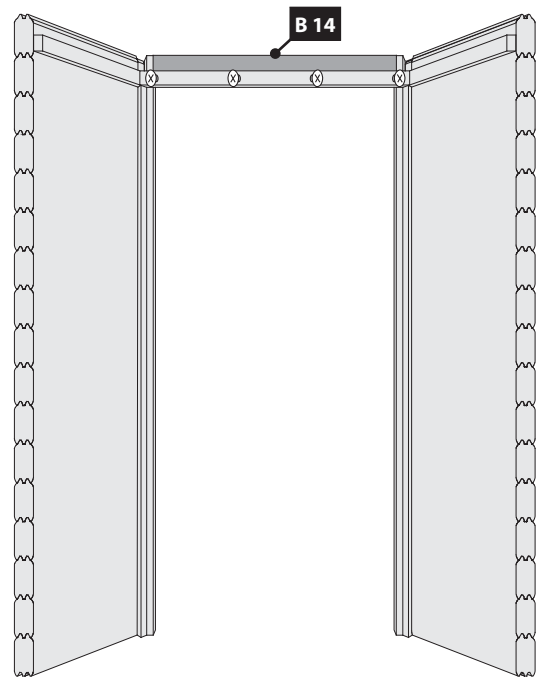
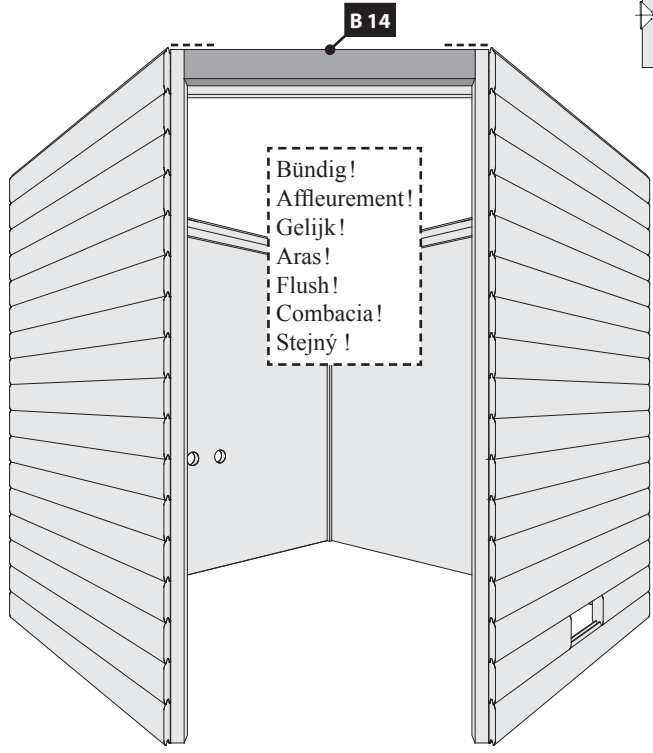
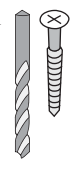
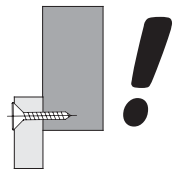

Ø3mm 4×50









-  Einbau Glastür
-  Montage porte en verre
-  Installation of glass door

-  Montage van de glazen deur
-  Montaje de la puerta de cristal

-  Installazione portello di vetro
-  Instalace skleněné dveře

!!! 01 — 03 !!!

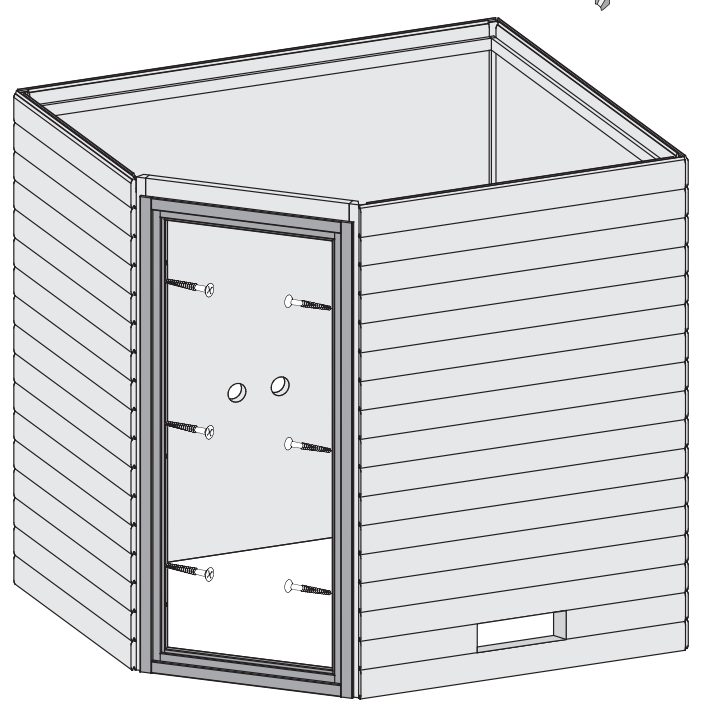
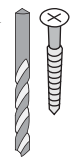
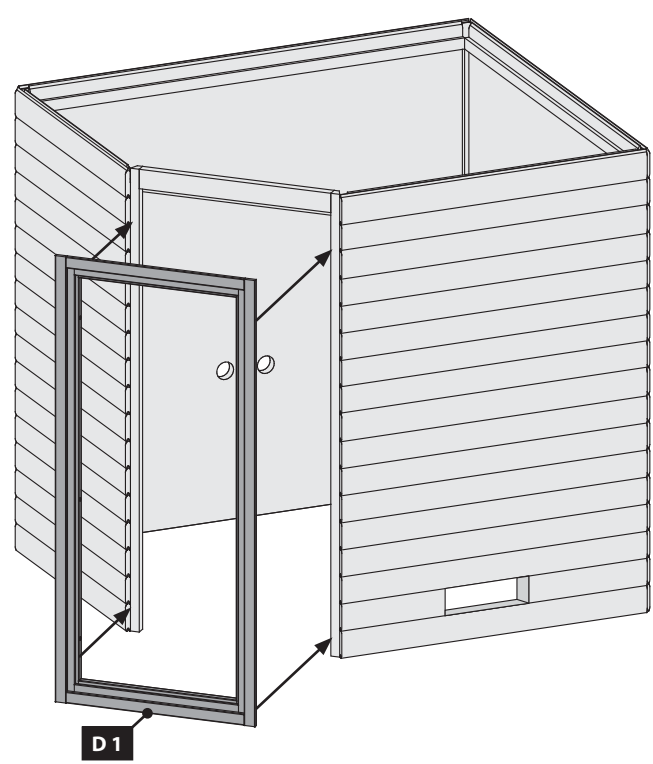

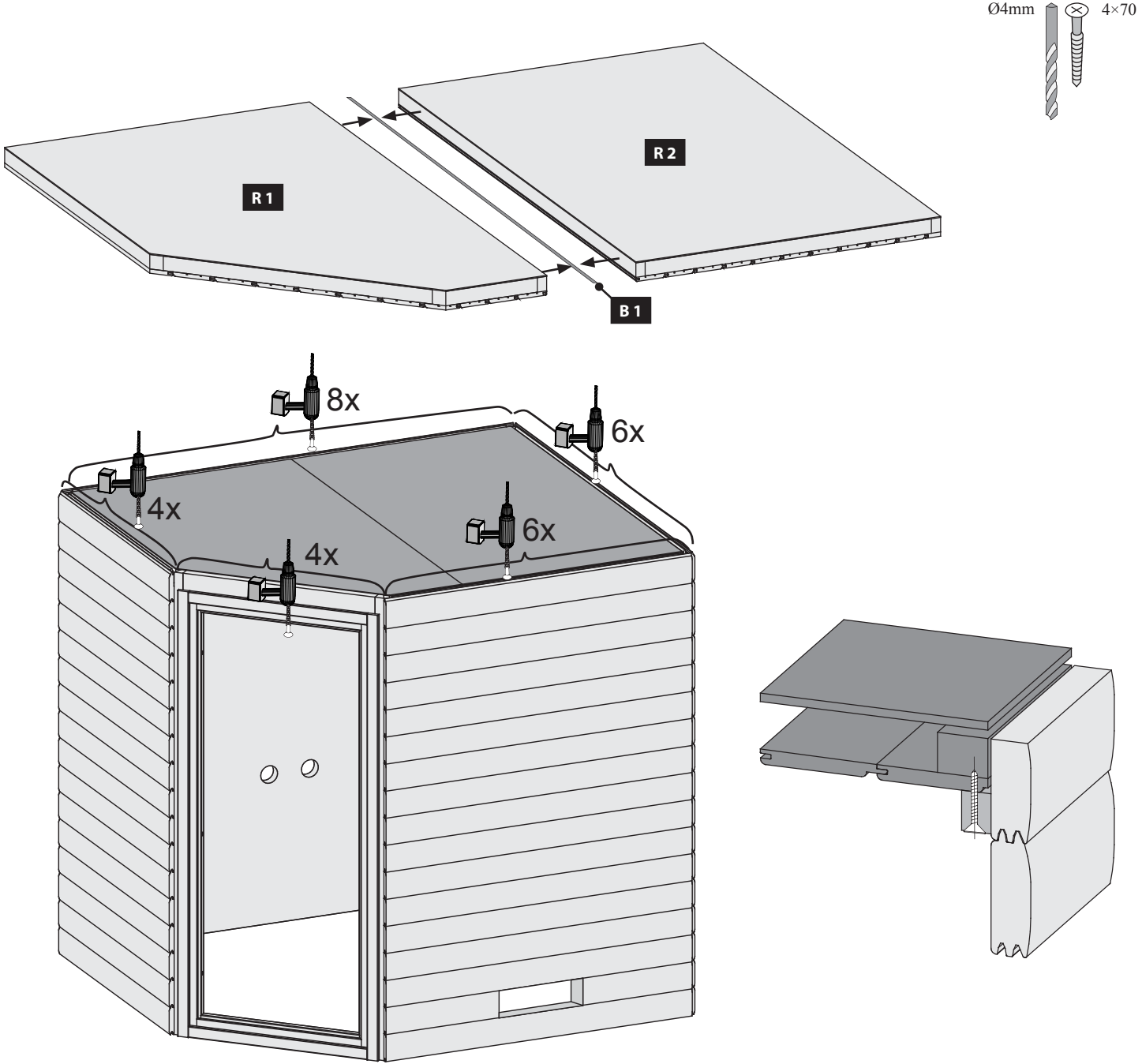
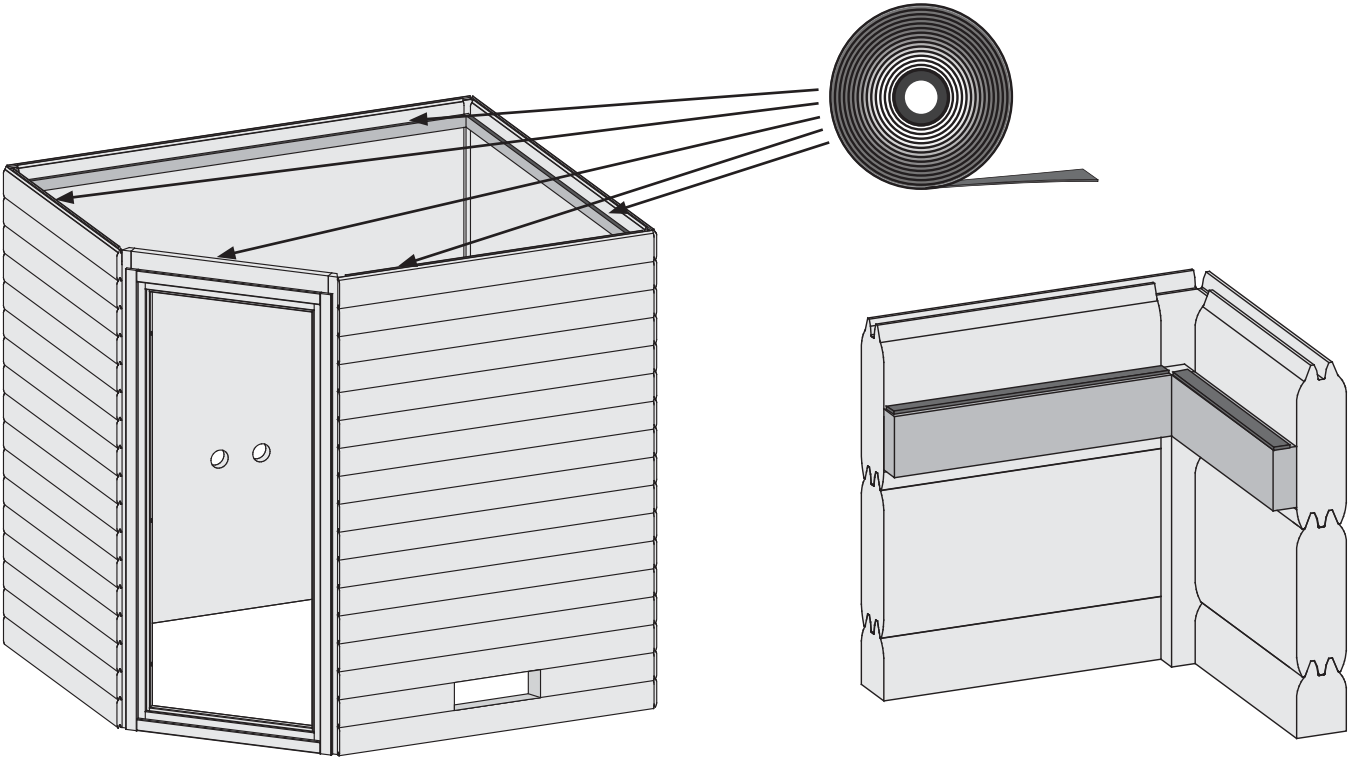

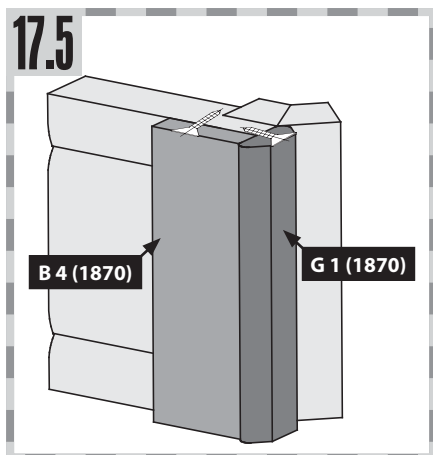
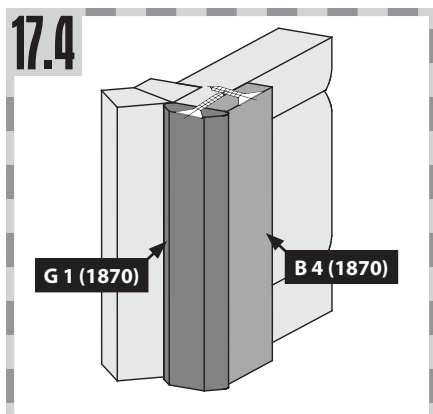
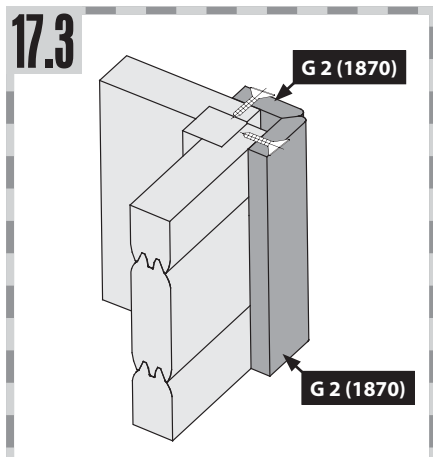
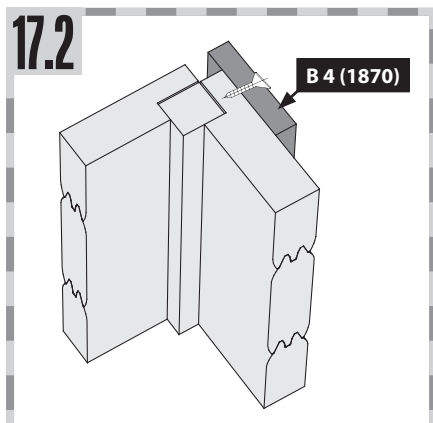
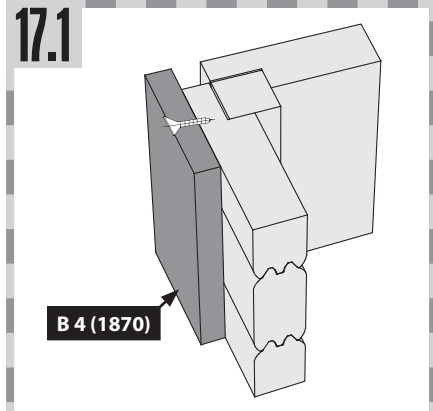
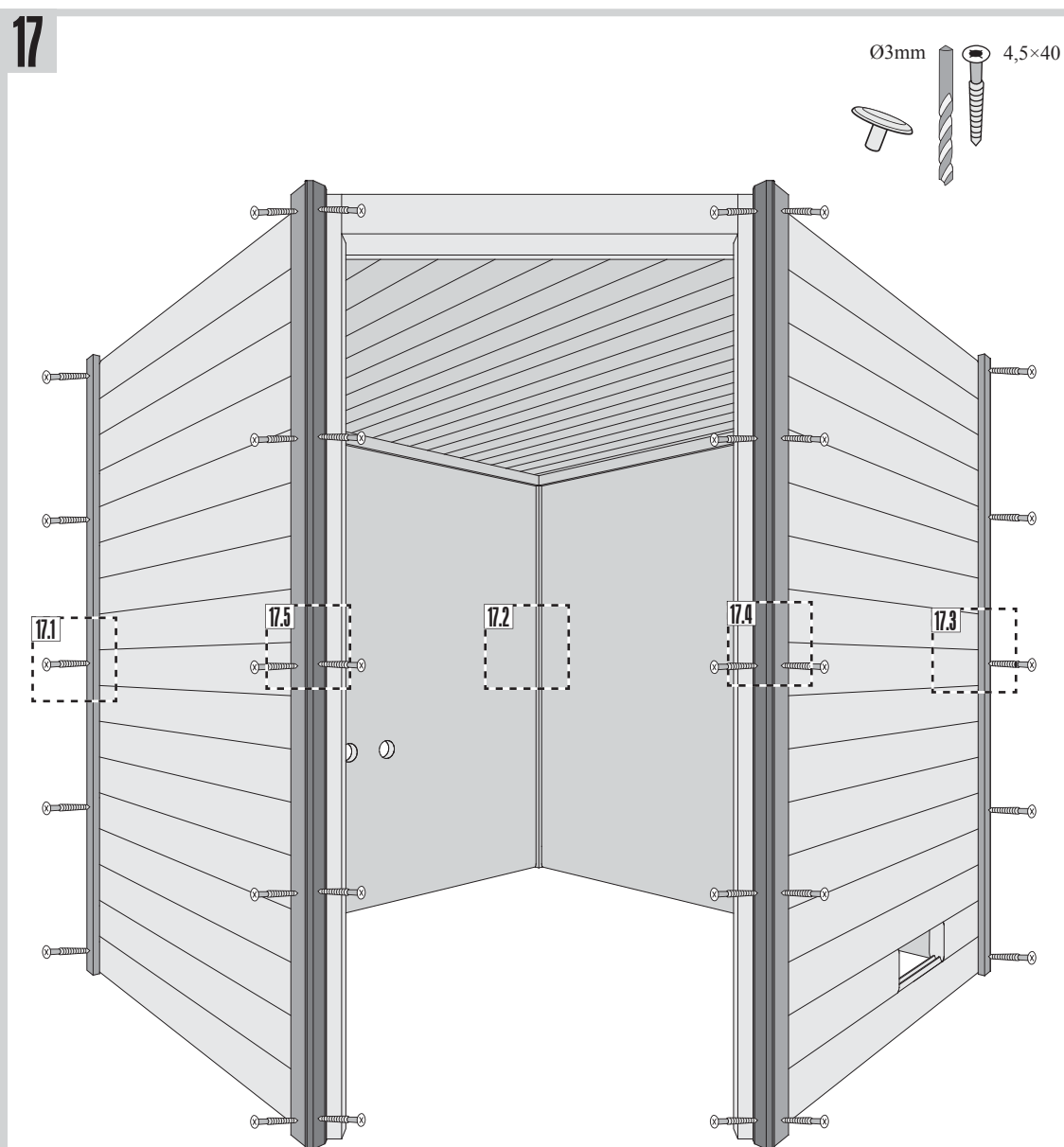
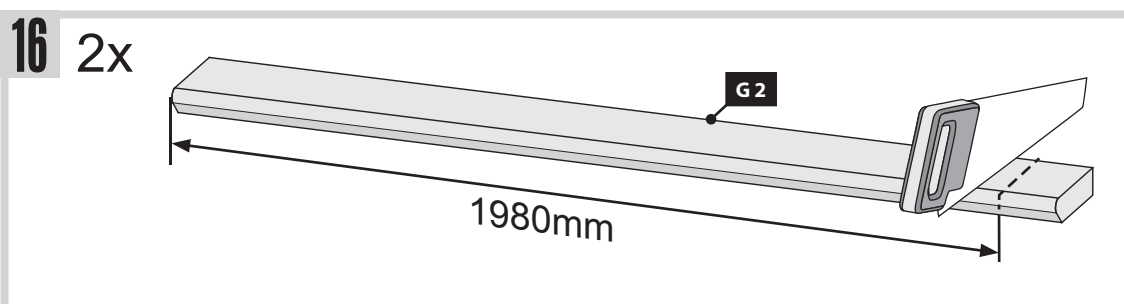
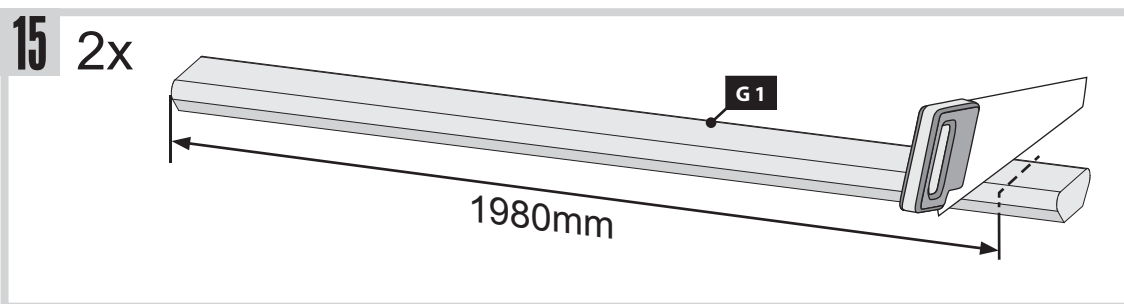
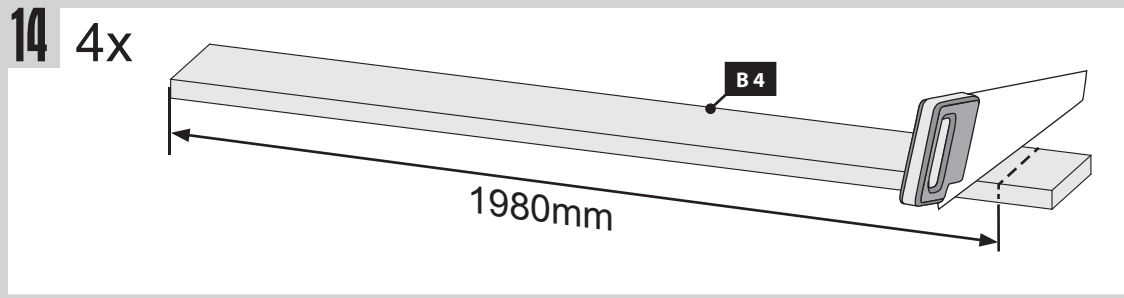

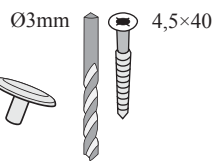

Bündig!  
 Affleurement!  
 Gelijk!  
 Aras!  
 Flush!  
 Combacia!  
 Stejný!

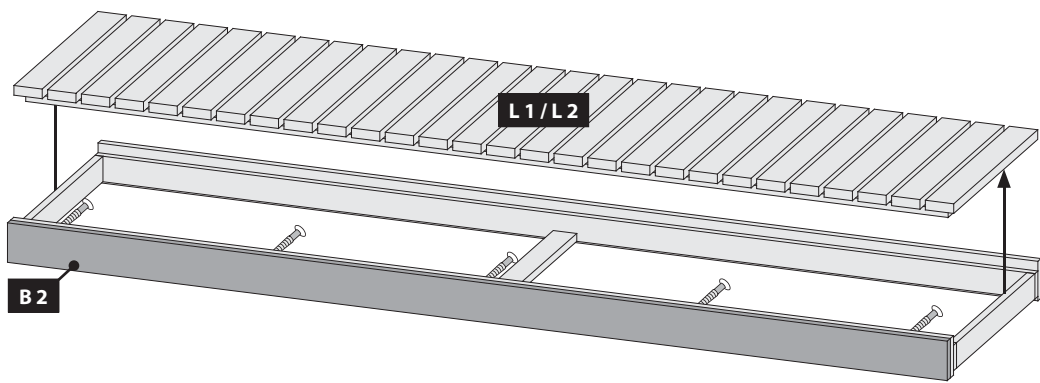
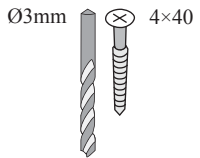
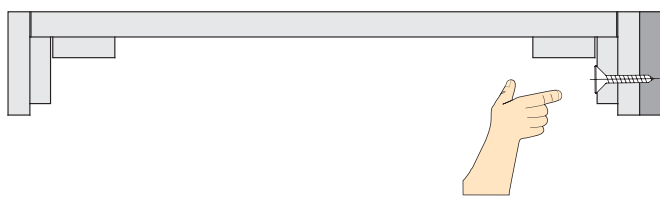
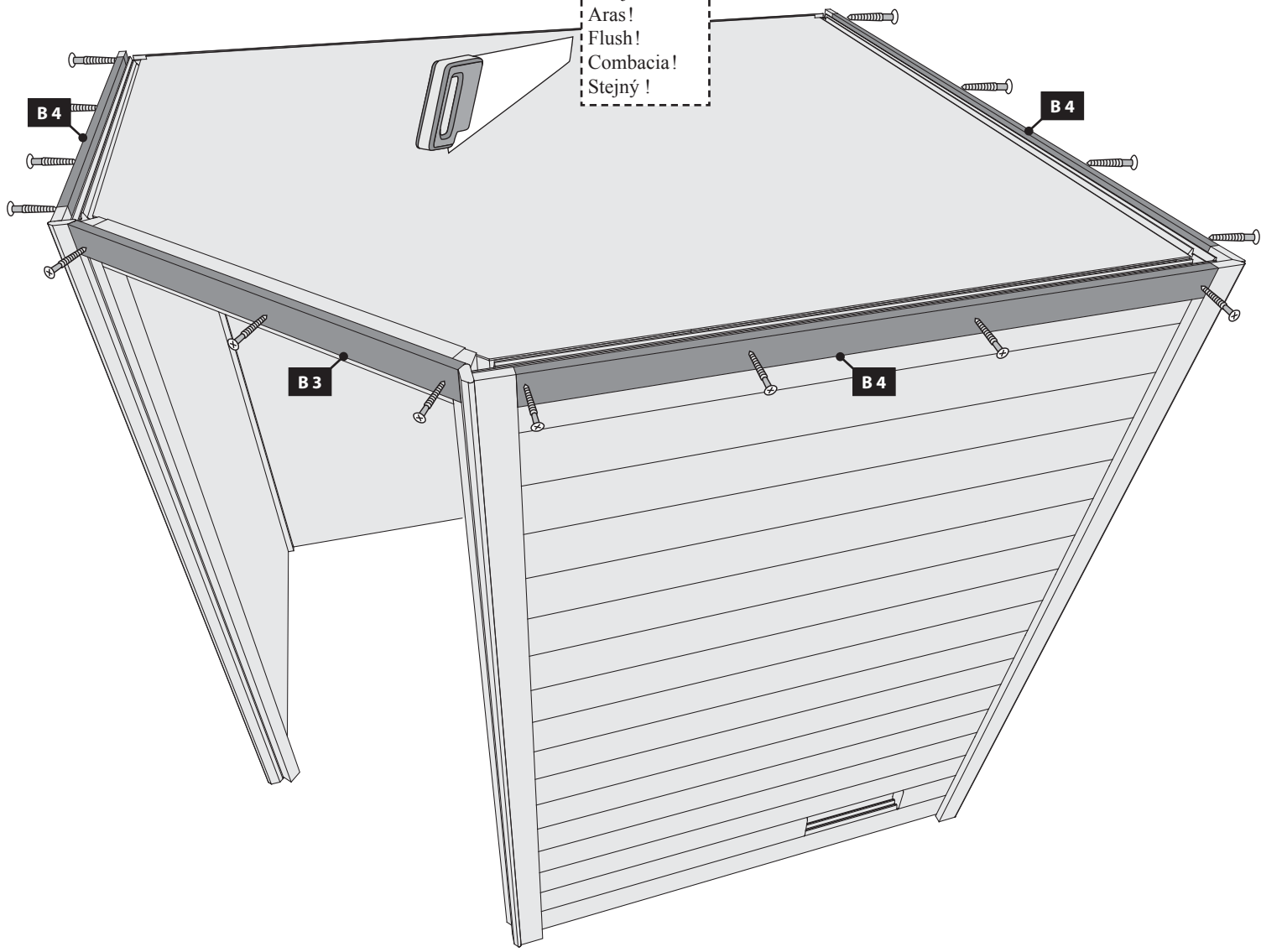

20 2x

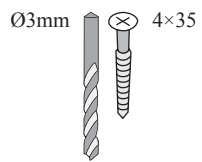
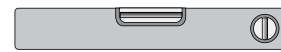
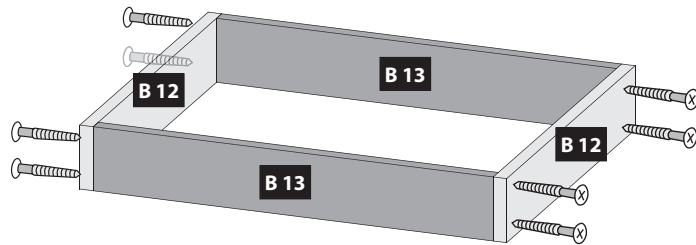

21 a

-  Nur bei 9 kW-Ofen
-  Seulement 9 kW chauffe
-  Only 9 kW heater
-  Slechts 9 kW heater
-  Sólo calentador de 9 kW
-  Solo riscaldamento 9 kW
-  Pouze topné těleso 9 kW

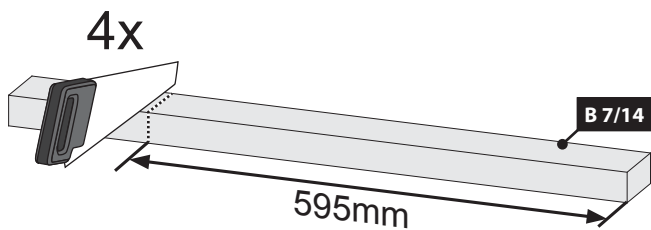
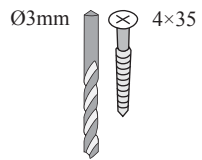
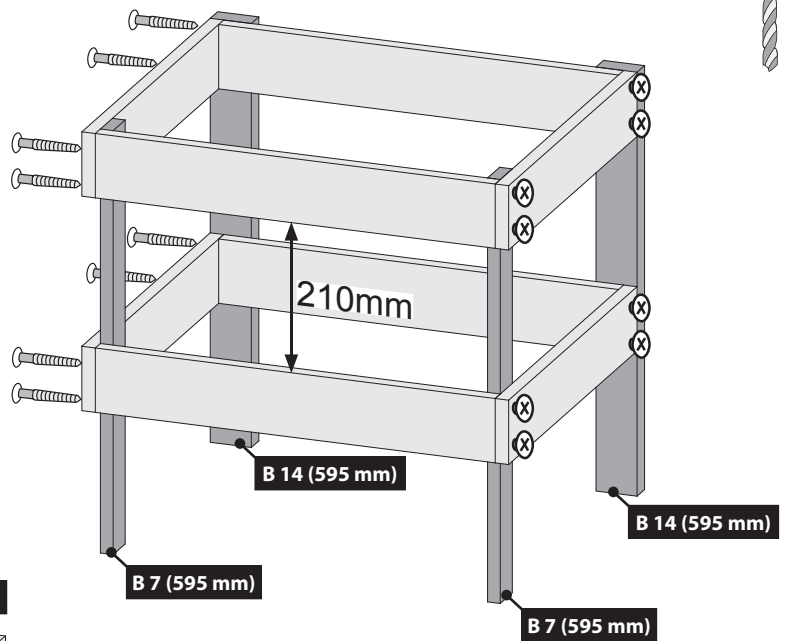

21 b

-  Bei allen anderen Öfen
-  Pour tous les autres fours
-  For all other furnaces
-  Voor alle andere ovens
-  Para todos los otros hornos
-  Per tutti gli altri tipi di forni
-  U všech ostatních pecích

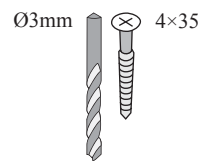
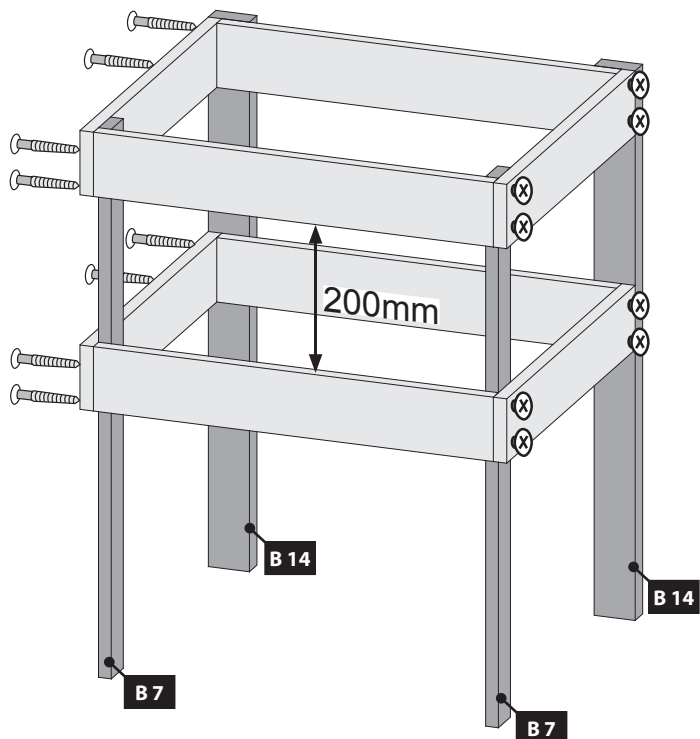

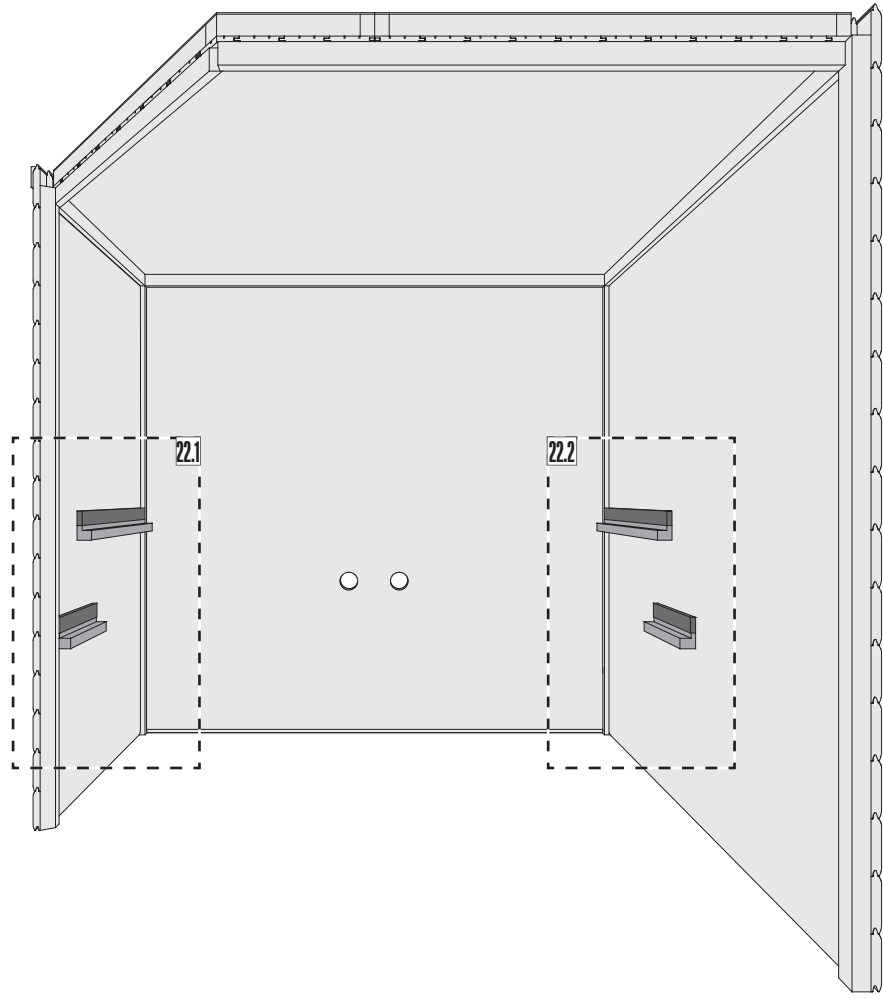

22.1-1

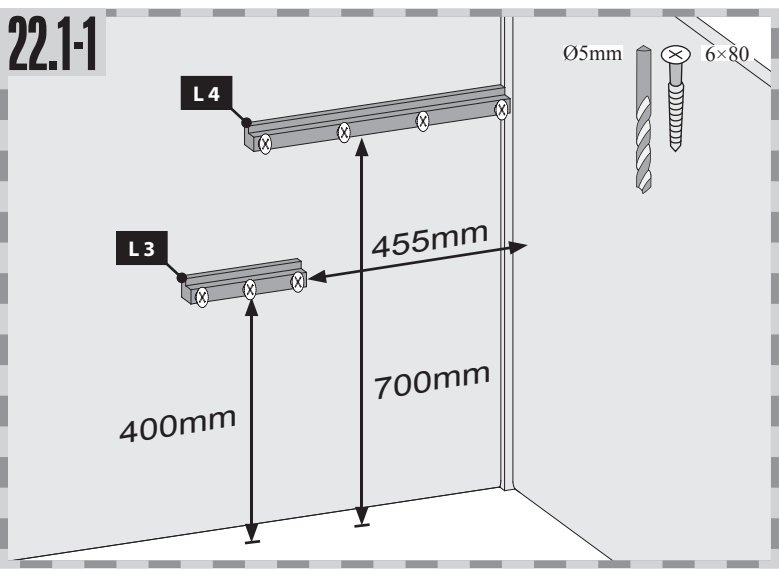

22.2-1

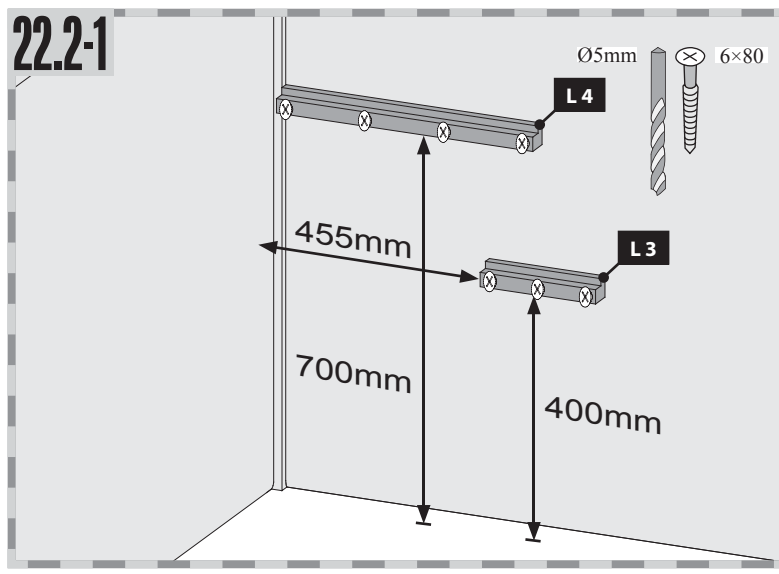

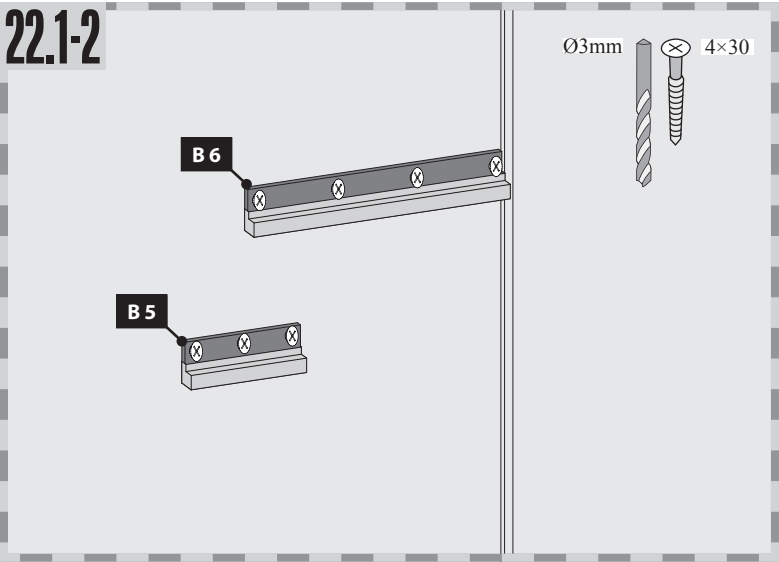

22.1-2



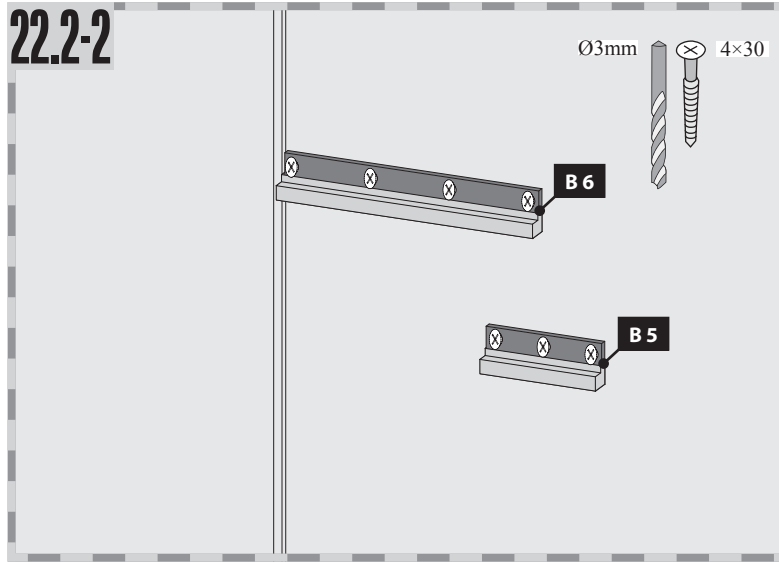

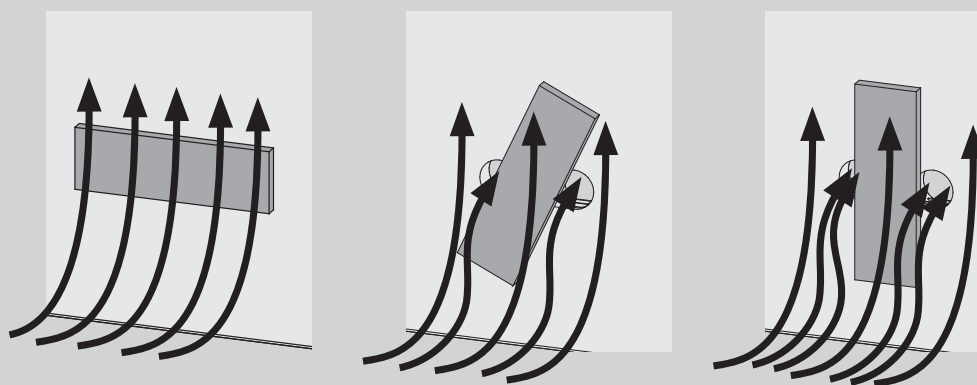
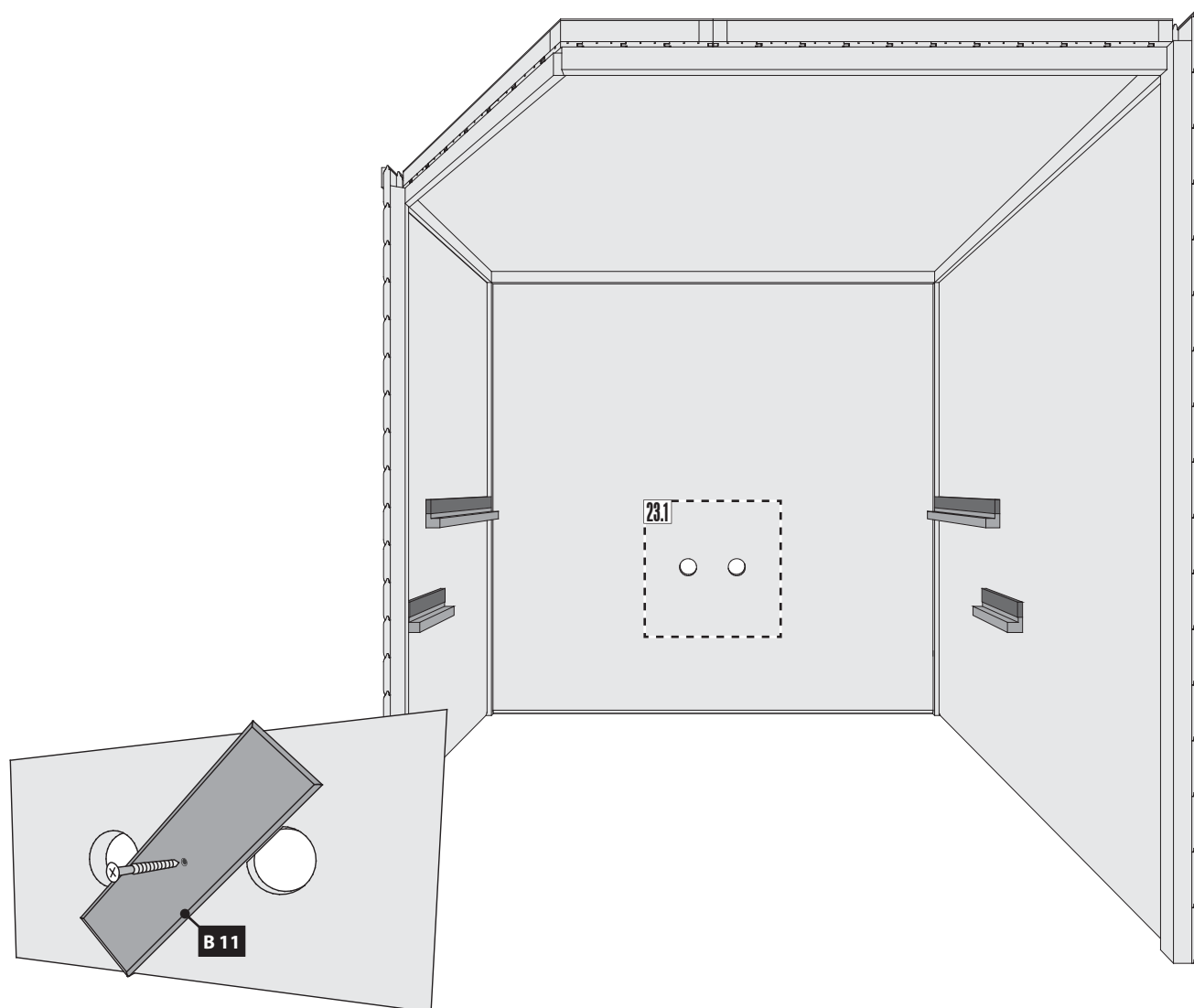
22.2-2







 Hier ist die Funktionsweise des Brettes abgebildet. Regeln Sie damit die Abluft nach Ihren eigenen Wünschen.

 Ceci représente le mode de fonctionnement de la planche. Avec elle, réglez l'écoulement de l'air selon vos désirs.

 This figure shows the functional principle of the board. Regulate the exhaust air according to your own wishes.

 Hier is de werking van het plankje afgebeeld. Regel daarmee de luchtafvoer naar eigen wens.

 Aquí está representada la forma de funcionamiento de la tabla. Regule con ello el aire de salida según sus propios deseos.

 Viene illustrato il principio di funzionamento della tavoletta di regolazione della ventilazione. Con essa si può regolare a piacere la ventilazione.

 Zde je zobrazená funkce desky. Regulujte s ní odsávací vzduch dle Vašeho přání.

24

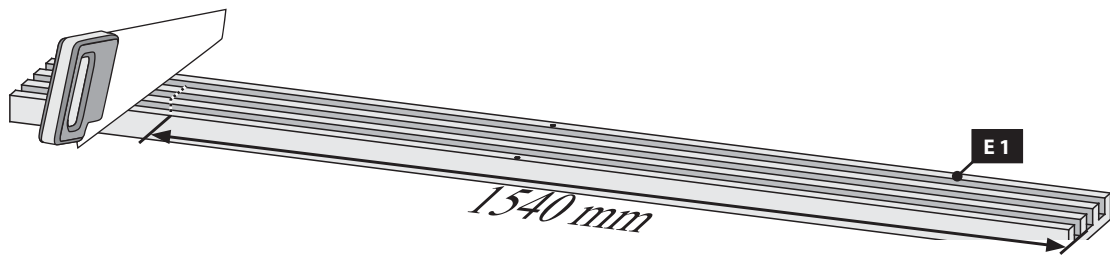

25

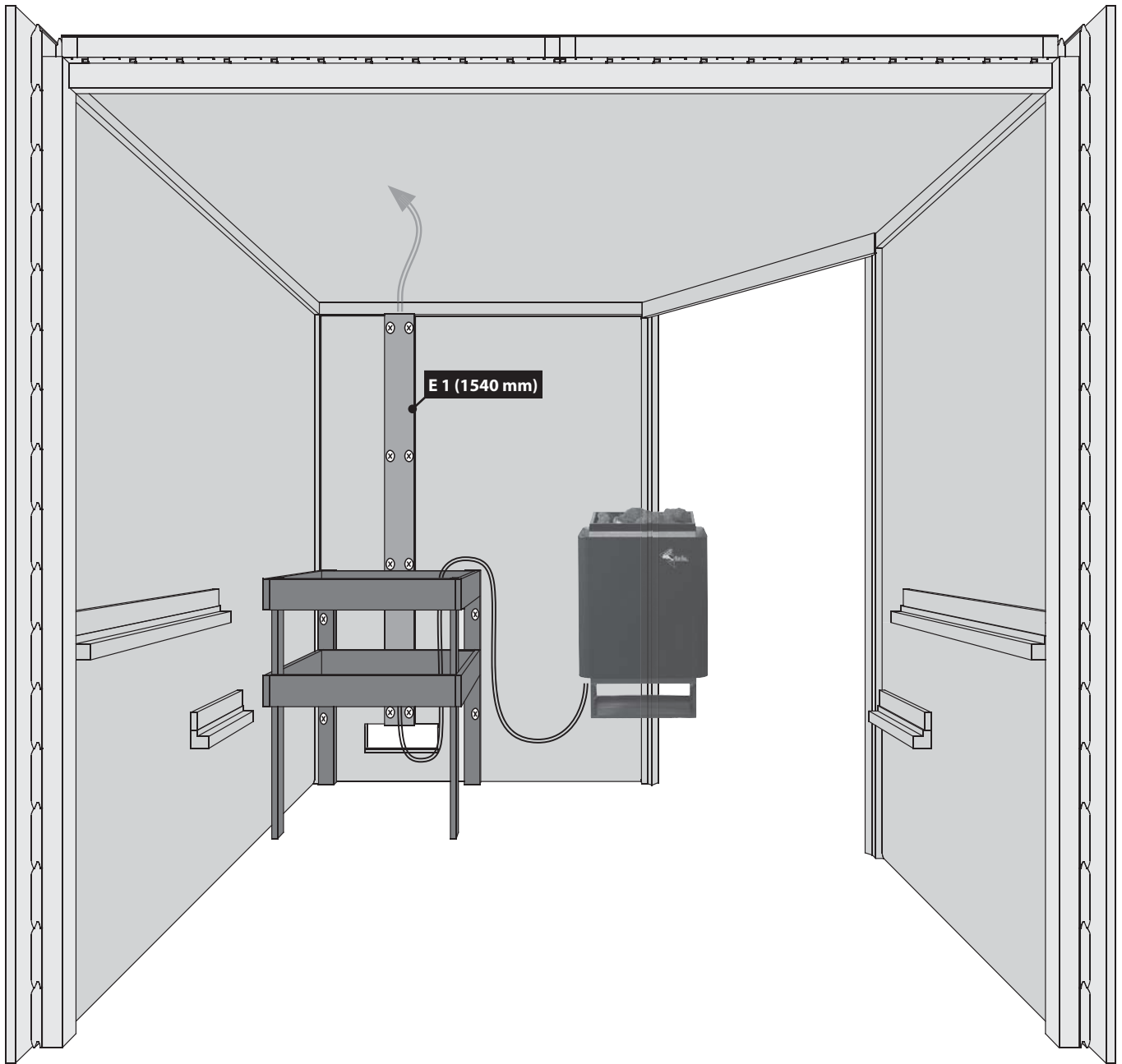
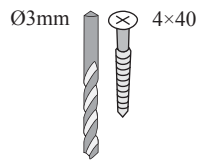



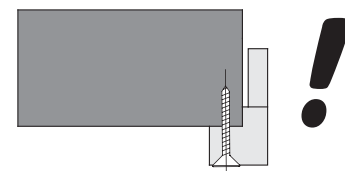
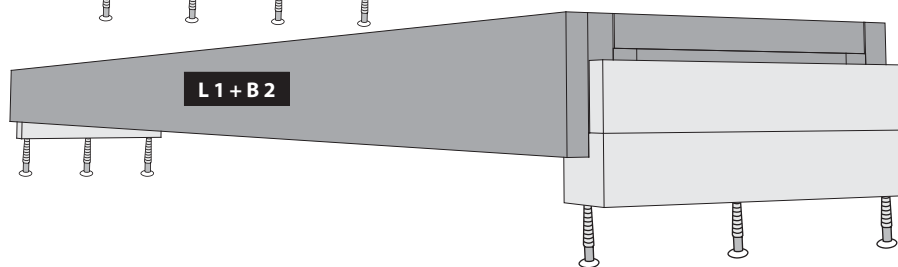
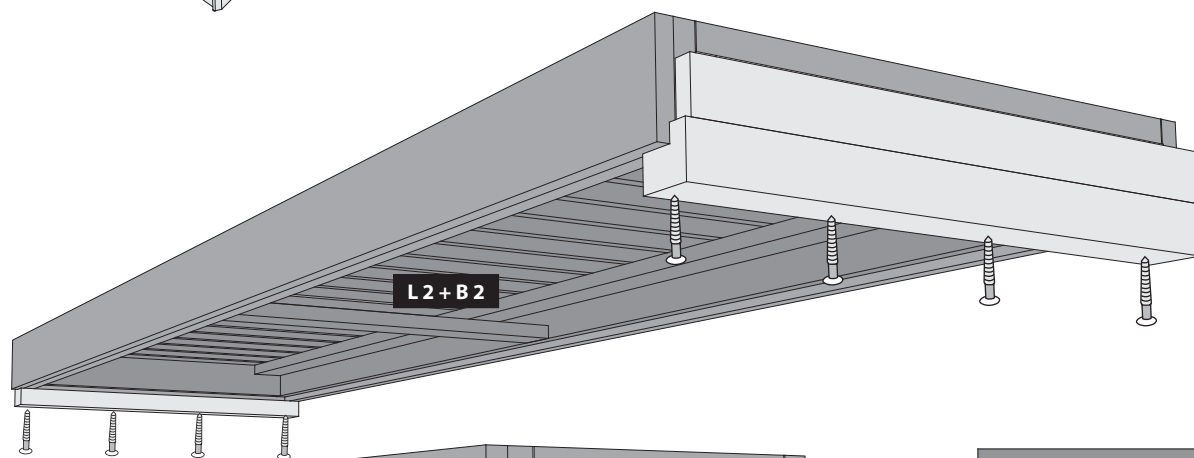
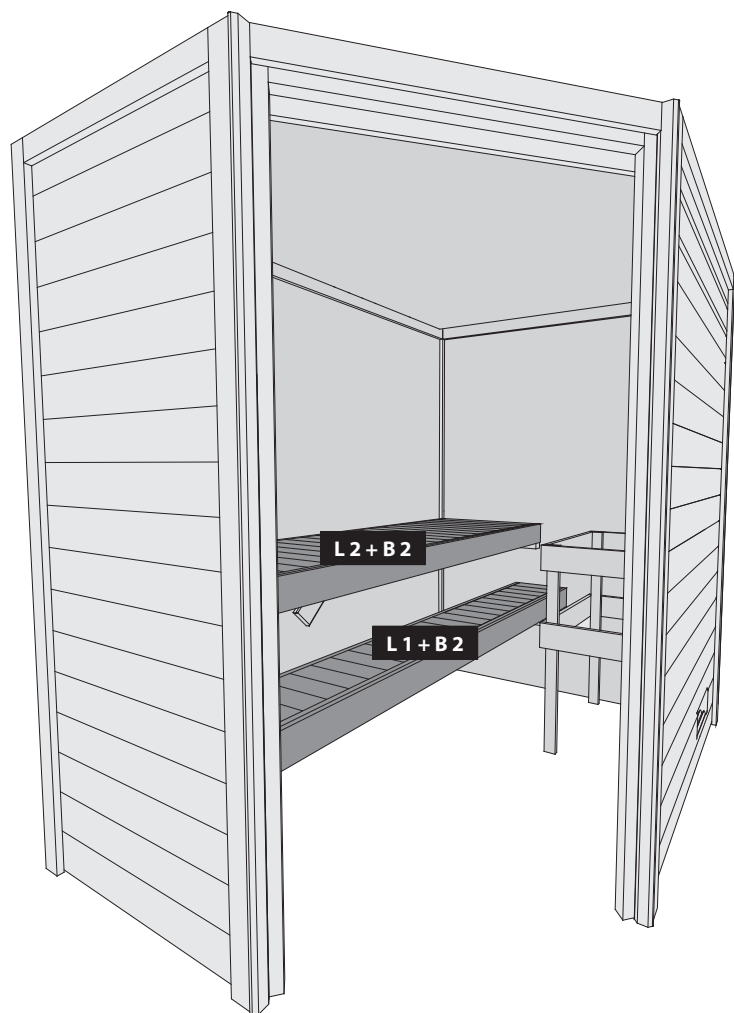
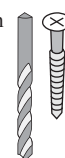

04 — 08



Einbau Glastür



Montage porte en verre



Installation of glass door



Montage van de glazen deur



Montaje de la puerta de cristal



Installazione portello di vetro



Instalace skleněné dveře